



Guide to Waterproofing Sheet Membranes

ARDEX Product Property Guide	2	Installation Specification	5
ARDEX Torch Applied Sheet Membrane	4	System Recommendations	6
APP Bitumen & SBS Sheet Membranes	4	Installation Details	7

DATASHEETS

NEW NAME	OLD NAME	NEW NAME	OLD NAME
ARDEX WPM 115	Shelterbit Vented Base Sheet	ARDEX WPM 3000X	Shelterseal 3000X Membrane
ARDEX WPM 116	Shelterbit Fibre Back Base Sheet	ARDEX WPM 5000HD	Shelterseal 5000HD Membrane
ARDEX WPM 120	Shelterbit 120 Membrane	ARDEX Shelterseal Associated Products	
ARDEX WPM 122	Shelterbit HD Bridge Membrane	– ARDEX WPM 249 Primer	Shelterseal Primer
ARDEX WPM 126		– ARDEX Pressure Seal	
ARDEX WPM 150	Shelterbit 3/160 Membrane	ARDEX Torch Applied Membranes Associated Products	
ARDEX WPM 180	Shelterbit 180 Membrane	– ARDEX WPM 240	
ARDEX WPM 185	Shelterbit Mineral Membrane	Butynol® Roofing	
ARDEX WPM 186	Shelterbit Garden Membrane	Butynol Installation Associated Products	
ARDEX WPM 191	Shelterbit SBS Cold Climate Membrane	– AREDX WPM 290 Solvent	
		– ARDEX WA 98 Adhesive	
		– ARDEX Seam Tape	
		– ARDEX Pressure Seal	
		– ARDEX Seam Primer	
		– ARDEX Butynol Sealant	

The information contained herein is to the best of our knowledge true and accurate. No warranty is implied or given as to its completeness or accuracy in describing the performance or suitability of the product for a particular application. Users are asked to check that the literature in their possession is the latest issue.

* "Guide to waterproofing liquid applied membranes" available separately.

ARDEX Product Property Guide

SHEET MEMBRANES		Type	Reinforcement Type		Rolls per Pallet	Roll Length (m)	Roll Width (m)	Normal Edge lap (mm)	Nominal Thickness/Weight per sq m	Surface Finish (top/bottom)
New Name	Old Name		type	Weight (gms)						
BUTYNOL ROOFING										
ARDEX Butynol 1.0	Butynol Standard	Butyl Rubber	n/a	n/a	n/a	17.86	1.4	50	1.0mm	Black
ARDEX Butynol 1.5	Butynol Medium					17.86	1.4	50	1.5mm	Black or Grey
ARDEX Butynol 2.25	Butynol Heavy Duty					17.86	1.4	50	2.25mm	Black
BASE SHEETS										
ARDEX WPM 115	Vented Base Sheet	APP Bitumen	glass	60	33	20	1.0	butt joint	0.8mm	torch film
ARDEX WPM 116	F/B Base Sheet		glass/poly	150+50	28	10	1.05	50	2.7mm	torch film/fleece
TORCH-ON MEMBRANES										
ARDEX WPM 120	120 Membrane	APP Bitumen	Combined Poly/Glass	120	23	15	1.0	75	2.5mm	sand/torch film
ARDEX WPM 160	3/150 Membrane			150	28	10	1.0	75	3.0mm	sand/torch film
ARDEX WPM 180	180 Membrane			180	23	10	1.0	75	3.5mm	sand/torch film
ARDEX WPM 185	Mineral Membrane			180	20	10	1.0	75	4.5kg	Grey, white, green slate/torch film
ARDEX WPM 186	Garden Membrane			180	23	10	1.0	75	3.5mm	sand/torch film
ARDEX WPM 122	HD Bridge Membrane			Poly	300	16	10	1.0	100	5.0mm
ARDEX WPM 195	4mm APAO	APAO Bitumen	Combined Poly/glass	180	20	10	1.0	100	4.0mm	sand/fleece
ARDEX WPM 196	4mm APAO Fleece Back			180	20	10	1.0	100	4.0mm	sand/torch film
ARDEX WPM 197	4mm APAO Mineral			180	20	10	1.0	100	5.4kg	mineral/torch film
ARDEX WPM 191	Fibrepol SBS	SBS	Poly	180	23	10	1.0	100	3.5	Torch film/torch film
SELF ADHESIVE SBS SHEETS										
ARDEX WPM 3000X	Shelterseal 3000	SBS	n/a	n/a	25	20	1.0	60mm	1.5	PE sheet
ARDEX WPM 5000HD	Shelterseal 5000HD				25	20	1.0	60mm	1.5	PP mesh

SHEET MEMBRANE ADHESIVES & SOLVENTS					
			Coverage	Dry Time	Clean Up
ARDEX WPM 240	Shelterbit Primer	Bitumen cut	5m ² /L	1-2 hours	ARDEX WPM 290
ARDEX WPM 249	Shelterseal Primer	Synthetic resins	5m ² /L	2-4 hours	ARDEX WPM 290
ARDEX WPM 245	F/B Base Adhesive	Synthetic resins	1.5	45 minutes	ARDEX WPM 290
ARDEX WPM 290	WA Solvent	Hydrocarbon	n/a	n/a	n/a
ARDEX WA 98	WA 98 Adhesive	Neoprene	2-2.5m ² /L	Tack time – 30 minutes	ARDEX WPM 290

PRODUCT WARRANTY

All ARDEX membrane systems are covered by product warranties provided by ARDEX. The length of the Product Warranty provided will depend upon the specific waterproofing system used. Contact ARDEX for more information regarding Warranties. All ARDEX systems should be installed by an approved experienced applicator.

ARDEX MODIFIED BITUMEN & SBS TORCH-ON MEMBRANES																		
	APP BASE SHEETS				APP MEMBRANE SHEETS				APAO MEMBRANE SHEETS				SPECIAL PURPOSE SHEETS					
	ARDEX WPM 115	ARDEX WPM 116	ARDEX WPM 120	ARRDEX WPM 160	ARDEX WPM 180	ARDEX WPM 185	ARDEX WPM 125	ARDEX WPM 126	ARDEX WPM 127	ARDEX WPM 186	ARDEX WPM 122	ARDEX WPM 191						
TECHNICAL PROPERTY	ARDEX SHELTERBIT VENTED BASE SHEET	ARDEX SHELTERBIT FIBRE BACK BASE SHEET	ARDEX SHELTERBIT 120	ARDEX SHELTERBIT 3/150	ARDEX SHELTERBIT 180	ARDEX SHELTERBIT MINERAL	FLEECE BASE SHEET	MEMBRANE	MINERAL	ARDEX SHELTERBIT GARDEN	ARDEX SHELTERBIT HD BRIDGE	ARDEX SHELTERBIT SBS COLD CLIMATE						
Type	APP	APP	APP	APP	APP	APP	APAO	APAO	APAO	APP	APP	SBS						
Reinforcement	Fibreglass (60g/m ²)	Fibreglass (50g/m ²)	Fibreglass & Polyester (120g/m ²)	Fibreglass & Polyester (150g/m ²)	Fibreglass & Polyester (180g/m ²)	Fibreglass & Polyester (180g/m ²)	Fibreglass & Polyester (180g/m ²)	Fibreglass & Polyester (180g/m ²)	Fibreglass & Polyester (180g/m ²)	Fibreglass & Polyester (300g/m ²)	Fibreglass & Polyester (180g/m ²)	Fibreglass & Polyester (180g/m ²)						
Thickness/weight	0.8mm	2.7mm	2.5mm	3.0mm	3.5mm	4.5 k/m ²	4.0mm	4.0mm	5.4 k/m ²	3.5mm	5.0mm	3.5mm						
Top Surface	Torch Film	Torch Film	Sand	Sand	Sand	Slate Chip	Sand	Sand	Slate Chip	Sand	Sand	Sand						
Bottom Surface	Torch Film	Polyester fleece (150g/m ²)	Torch Film	Torch Film	Torch Film	Torch Film	Polyester Fleece	Torch Film	Torch Film	Torch Film	Torch Film	Torch Film						
Tear Resistance (longitudinal)	70 N	100 N	120 N	130 N	130 N	130 N	180 N	180 N	180 N	130 N	200 N	160 N						
Elongation (longitudinal)	-	60%	35%	45%	40%	40 %	45%	45%	45%	40%	45%	45%						
Heat Stability	110°C	110°C	110°C	110°C	110°C	110°C	140°C	140°C	140°C	110°C	120°C	90°C						
Cold Flexibility	- 5°C	- 5°C	- 5°C	- 5°C	- 5°C	- 5°C	- 35°C	- 35°C	- 35°C	- 5°C	- 10°C	- 20°C						
Roll Size	1x20m	1x10m	1x15m	1x10m	1x10m	1x10m	1X10m	1X10m	1X10m	1x10m	1x10m	1x10m						
Roll Weight (approx.)	20kg	30kg	43.5kg	35kg	42kg	45kg	40kg	40kg	54kg	42kg	52kg	43kg						

ARDEX Torch Applied Membrane

(Shelterbit Sheet Membranes)

APP Bitumen & SBS Sheet Membranes

The Sheet Membrane range of waterproofing products incorporates bituminous sheet membranes for a wide variety of roofing and tanking situations. The range comprises both APP, APAO and SBS torch applied products. Details for each product are contained in the individual Product Data Sheet.

PRODUCTS

ARDEX WPM 115

0.8mm APP Bitumen Vented Base Sheet (Shelterbit Vented Base Sheet)

A fibreglass reinforced polymer APP modified bituminous membrane perforated with 40mm diameter holes. The sheet is covered with heat sensitive polythene film on both sides and is used as a base layer to allow dispersion of vapour in exposed bitumen sheet waterproofing systems.

ARDEX WPM 116

2.7mm APP Bitumen Fibre backed base sheet (Shelterbit Fibre-backed Base Sheet)

A polyester backed fibreglass reinforced modified bituminous membrane normally installed as a base layer in multi-layer Shelterbit systems. ARDEX WPM 116 (Shelterbit fibre-backed base sheet) has been specially designed for application to heat sensitive substrates such as timber or thermal insulation. It is also ideally suited for use as a base layer on rough or uneven surfaces, over sound existing membranes such as rubber, PVC, bitumen, acrylic and polyurethane or over insulation. It can be loose laid, mechanically fastened, adhered with Shelter adhesives or laid in hot-melt bitumen using the hot roll and pour method.

ARDEX WPM 120

2.5mm Combined reinforced APP Bitumen Membrane (Shelterbit 120 Membrane)

A 2.5mm (nominal) thick combined reinforced (polyester & fibreglass) APP modified bituminous torch applied membrane. It is used as a base or mid layer in a multi-layer bituminous membrane system.

ARDEX WPM 150

3.0mm Combined reinforced APP Bitumen Membrane

A 3.0mm (nominal) thick combined reinforced (polyester & fibreglass) APP modified bituminous torch applied membrane. It is used as a base or mid layer in a multi-layer bituminous membrane system.

ARDEX WPM 180

3.5mm Combined reinforced APP Bitumen Membrane (Shelterbit 180 Membrane)

A 3.5mm (nominal) thick combined reinforced (polyester & fibreglass) APP modified bituminous torch applied membrane. It is used as a single layer tanking membrane for horizontal or vertical applications, and may also be used in a multi-layer membrane system.

ARDEX WPM 185

4.5kg/m² Mineral Coated APP Bitumen Membrane (Shelterbit Mineral Membrane)

A 4.0mm (nominal) thick combined reinforced (polyester & fibreglass) APP modified bituminous torch applied membrane with a mineral slate finish. Designed as a cap layer in exposed membrane systems. Available in grey, green and white.

ARDEX WPM 186

3.5mm Garden APP Bitumen Membrane (Shelterbit Garden Membrane)

A 3.5mm (nominal) thick combined reinforced (polyester & fibreglass) APP modified bituminous torch applied membrane formulated with root inhibitors to prevent damage from plant roots. ARDEX WPM 186 has been purpose designed for waterproofing landscape and planter box areas, and can be used in single or multi-layer systems.

ARDEX WPM 122

5.0mm Heavy Duty Bridge & Deck APP Bitumen Membrane (Shelterbit HD Bridge Membrane)

A heavy duty 5.0mm (nominal) thick non-woven polyester reinforced APP modified bituminous membrane designed for use on bridges and car parks. The heavy duty polyester reinforcement (300g/m²) allows hot road base to be applied directly to the installed membrane.

ARDEX WPM 125

4.0mm APAO Bitumen Fibre backed base sheet

Providing all the properties of ARDEX WPM 126, ARDEX WPM 125 is backed with a polyester fibre. ARDEX WPM 125 has been specially designed for application to heat sensitive substrates such as timber or thermal insulation, moisture containing substrates and over sound existing membranes such as rubber, PVC, bitumen, acrylic and polyurethane.

ARDEX WPM 126

4.0mm Combined reinforced APAO Bitumen Membrane

A 4.0mm (nominal) thick premium combined reinforced (polyester & fibreglass) APAO modified bituminous torch applied membrane providing the properties of APP while at the same time providing the low temperature resistant properties normally attributed to SBS. ARDEX WPM 126 has a service temperature tolerance of between -35°C and 140°C.

ARDEX WPM 127

4.5kg/m² Mineral Coated APAO Bitumen Membrane

Providing all the properties of ARDEX WPM 126, ARDEX WPM 127 also contains slate chips fused into the upper surface for protection in exposed applications.

ARDEX WPM 191

3.5mm SBS Bitumen Membrane (Shelterbit SBS Cold Climate Membrane)

A 3.5mm (nominal) thick combined reinforced (polyester & fibreglass) SBS rubber modified bituminous membrane. Used in single or multi-layer systems in horizontal or vertical tanking applications. ARDEX WPM 191 is ideal for use in cooler climates because of its ease of workability.

Installation Specification

This recommendation has been prepared for the general installation of an ARDEX Torch Applied Membrane System. Each project can have its own special conditions and idiosyncrasies that may require special conditions and/or processes of installation. Confirmation of the suitability for this recommendation in relation to any project should be sought from the ARDEX Representative prior to specifying.

The application of ARDEX torch applied membranes should be carried out by an Approved Installer of ARDEX waterproofing membranes. Installation shall be strictly in accordance with the Manufacturer's recommendations. All materials used in conjunction with the ARDEX Torch Applied Membrane Systems must be approved by ARDEX.

STORAGE AND HANDLING

Rolls of membrane delivered to the site are to be stored in a covered area or be covered with a protective sheet until required for installation. Rolls are to be stored vertically taking care to prevent damage to the ends. Rolls are not to be dropped or mishandled.

SURFACE PREPARATION

Surfaces to which the ARDEX Torch Applied Membrane Systems are installed must be properly prepared prior to installation. All surfaces must be clean, dry, smooth, free of sharp edges, fines, loose or foreign materials, oil, grease and other materials which may damage the membrane. Concrete must be 28 days old, screeds must be 7 days and substrate must be dry.

Sand/cement fillets are recommended at all change in direction of substrate (from horizontal to vertical).

Plywood substrates should be structurally sound, fixed with 3mm gaps between all sheets, and countersunk screws fixed to plywood manufacturer's specifications. **Staples and nails are not suitable under any circumstances.** Wooden substrates with right angled internal corners should have a timber triangular fillet 50mm x 50mm screwed to each corner. External corners should be rounded to reduce wear on edges and allow an improved finish.

Commencement of laying shall be taken as acceptance of the substrate by the Applicator.

PRIMING

Prior to the application of ARDEX Torch Applied Membranes, all prepared surfaces shall be primed with ARDEX WPM 240 primer at a rate of 5-6m² per litre and allowed to dry.

Coverage of primer may vary depending on the density or porosity of the substrate. Primer may be applied by brush, roller or spray equipment. Coverage must be uniform.

Note that priming is not required for the installation of ARDEX WPM 116 or WPM 125 Base Sheets.

MEMBRANE SYSTEM COMBINATION

ARDEX Torch Applied Membranes can be used in various combinations, refer to ARDEX Torch Applied Membrane System Recommendation in this section for your individual waterproofing requirement.

TESTING

After installation, it is recommended, where possible, a water test be carried out for 24 hours.

PROTECTION

An ARDEX protection board must be used prior to backfilling or when topping is required.

SAFETY PRECAUTIONS

ARDEX Torch Applied Membranes are non-dangerous goods. However, during installation, exercise extreme caution when working with open flame.

Do not use open flame directly on highly combustible material. Follow all local fire codes.

ARDEX Torch Applied Membrane

System Recommendations

ARDEX Torch Applied waterproofing membranes can be used in a wide variety of combinations to suit the requirements of a specific waterproofing application. The following table outlines most of the acceptable alternatives for a range of common situations encountered. Please consult with your local ARDEX representative to select the most appropriate solution.

TORCH APPLIED SYSTEMS

Systems for concrete or topping substrates:

Spec.

No. System

SINGLE LAYER NON EXPOSED SYSTEMS	
01	One layer of ARDEX WPM 120 (Shelterbit 120)
02	One layer of ARDEX WPM 180 (Shelterbit 180) OR
03	One layer of ARDEX WPM 191 (Shelterbit SBS Cold Climate Membrane)
TWO LAYER NON EXPOSED SYSTEMS	
04	1st layer of ARDEX WPM 120 (Shelterbit 120) 2nd layer of ARDEX WPM 180 (Shelterbit 180) OR
05	1st layer of ARDEX WPM 191 (Shelterbit SBS Cold Climate Membrane) 2nd layer of ARDEX WPM 191 (Shelterbit SBS Cold Climate Membrane)
THREE LAYER NON EXPOSED SYSTEM	
06	1st layer ARDEX WPM 120 (Shelterbit 120) 2nd layer ARDEX WPM 120 (Shelterbit 120) 3rd layer ARDEX WPM 180 (Shelterbit 180)
TWO LAYER EXPOSED SYSTEMS	
07	1st layer of ARDEX WPM 120 (Shelterbit 120) 2nd layer of ARDEX WPM 185 (Shelterbit Mineral with Slate Mineral chip) OR
08	1st layer ARDEX WPM 180 (Shelterbit 180) 2nd layer ARDEX WPM 185 (Shelterbit Mineral with Slate Mineral chip).
TWO LAYER VENTED EXPOSED SYSTEMS	
09	1st layer ARDEX WPM 116 (Shelterbit Fibre Backed Base sheet) (glued in) 2nd layer ARDEX WPM 185 (Shelterbit Mineral with Slate Mineral chip) OR
10	1st layer ARDEX WPM 115 (Shelterbit Vented Base sheet) 2nd layer ARDEX WPM 185 (Shelterbit Mineral with Slate Mineral chip) OR
THREE LAYER VENTED EXPOSED SYSTEMS	
11	1st layer ARDEX WPM 115 (Shelterbit Vented Base Sheet) 2nd layer ARDEX WPM 180 (Shelterbit 180) 3rd layer ARDEX WPM 185 (Shelterbit Mineral with Slate Mineral chip) OR

12	1st layer ARDEX WPM 116 (Shelterbit Fibre Backed Base sheet) 2nd layer ARDEX WPM 120 (Shelterbit 120) 3rd layer ARDEX WPM 185 (Shelterbit Mineral with Slate Mineral chip).
SINGLE LAYER GARDEN & LANDSCAPE SYSTEM	
13	One layer of ARDEX WPM 186 (Shelterbit Garden)
TWO LAYER GARDEN & LANDSCAPE SYSTEM	
14	1st layer ARDEX WPM 120 (Shelterbit 120) 2nd layer ARDEX WPM 186 (Shelterbit Garden)
BRIDGE WATERPROOFING SYSTEM	
15	One layer ARDEX WPM 122 (Shelterbit HD Bridge Membrane)

Systems for timber or other non-torchable substrates:

Spec.

No. System

TWO LAYER NON EXPOSED SYSTEM	
16	1st layer ARDEX WPM 116 (Shelterbit Fibre Backed Base sheet) (glued in) 2nd layer ARDEX WPM 180 (Shelterbit 180)
TWO LAYER EXPOSED SYSTEM	
17	1st layer ARDEX WPM 116 (Shelterbit Fibre Backed Base sheet) (glued in) 2nd layer ARDEX WPM 185 (Shelterbit Mineral with Mineral Slate chip).
THREE LAYER EXPOSED SYSTEM	
18	1st layer ARDEX WPM 116 (Shelterbit Fibre Backed Base sheet) (glued in) 2nd layer ARDEX WPM 120 (Shelterbit 120) 3rd layer ARDEX WPM 185 (Shelterbit Mineral with Mineral Slate chip.)

Systems for application over insulation:

Spec.

No. System

19	1st Layer ARDEX WPM 116 (Shelterbit Fibre Backed Base sheet) (mechanically fixed) 2nd ARDEX WPM 185 (Shelterbit Mineral with Mineral Slate chip.)
20	1st ARDEX WPM 116 (Shelterbit Fibre Backed Base sheet) (mechanically fixed) 2nd ARDEX WPM 120 (Shelterbit 120) 3rd ARDEX WPM 185 (Shelterbit Mineral with Mineral Slate chip.)

Installation Details

SHEET LAYOUT

Application Details Two Plies System

Staggered Layout for Finish Membrane

- 1 – First layer
- 2 – Second layer
- 3 – Third layer

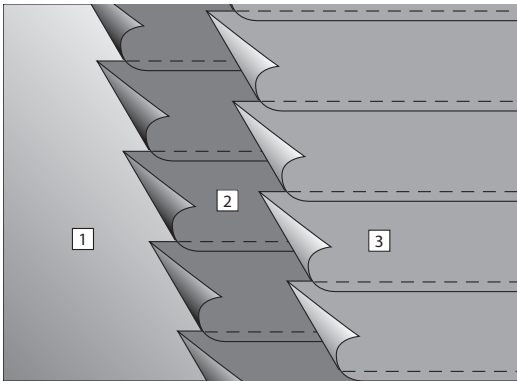

TYPICAL TURN UP DETAILS – NON-EXPOSED MEMBRANE

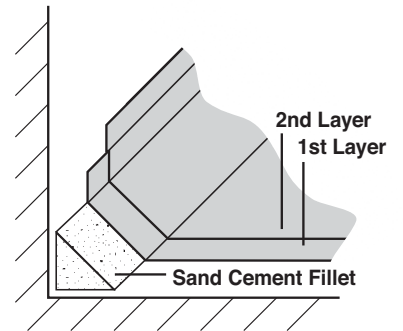
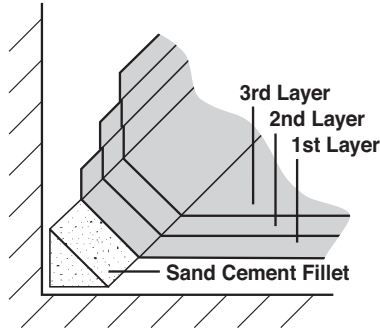

TYPICAL TURN UP DETAILS – EXPOSED MEMBRANE

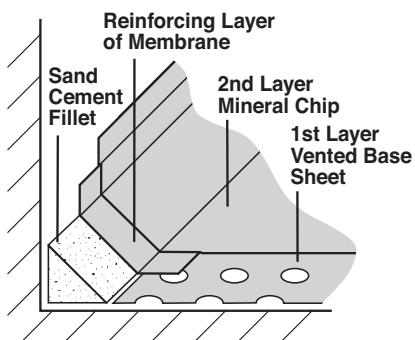
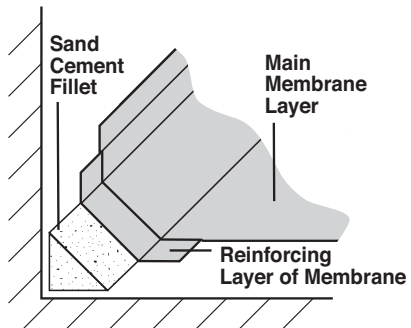
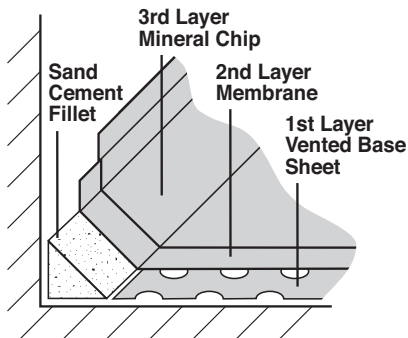

PRESSURE SEAL FLASHING

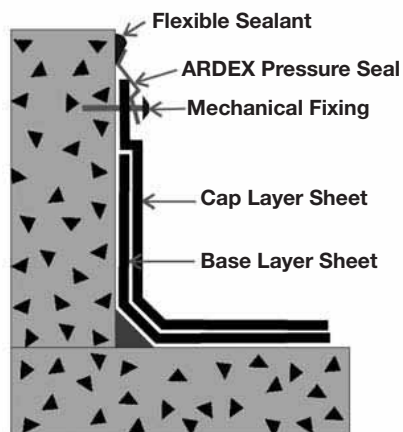

ARDEX Torch Applied Membrane

Installation Details

CUT IN FLASHING

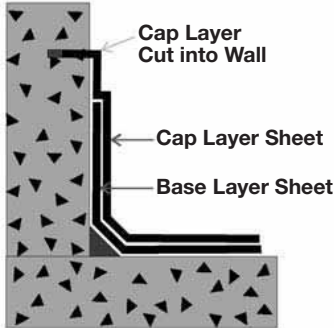

CONSTRUCTION JOINT

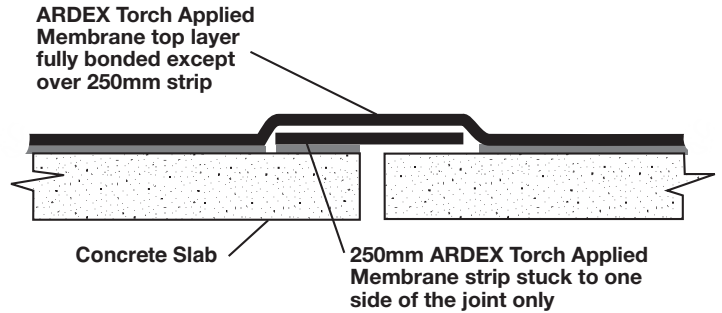

LIQUID MEMBRANE FLASHING

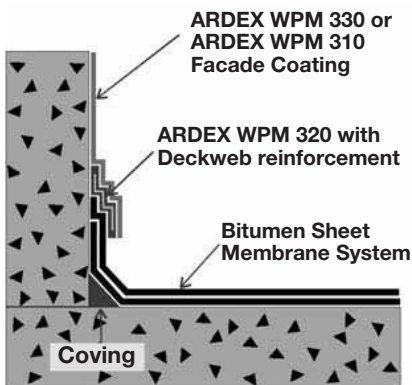

EXPANSION JOINT

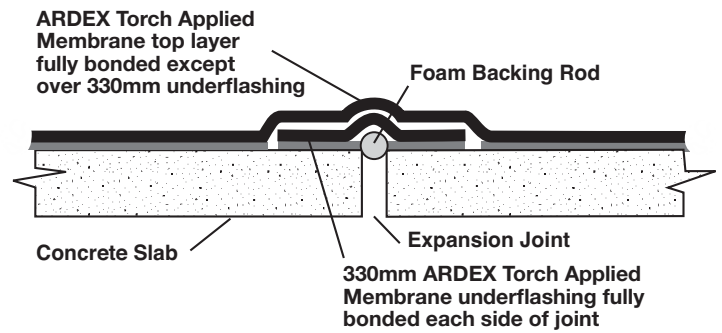

CAPPING DETAIL

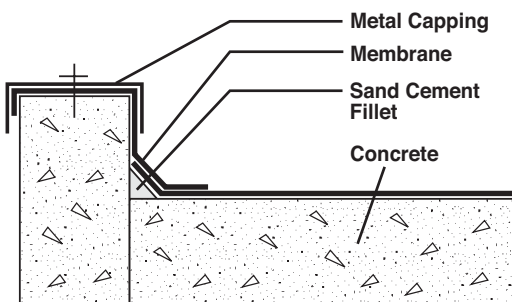

ALTERNATE EXPANSION JOINT

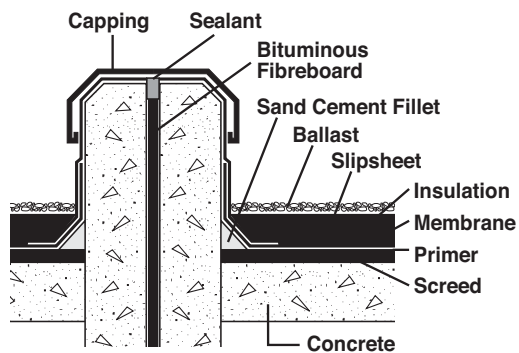

GARDEN BED/PLANTER BOX DETAIL

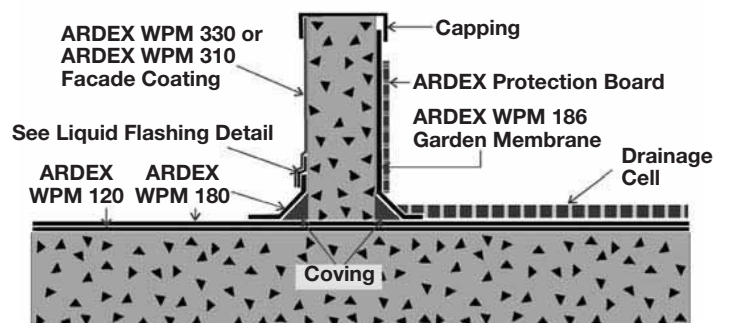

**MECHANICAL FIXING OVER FOAM
2 LAYER SYSTEM**

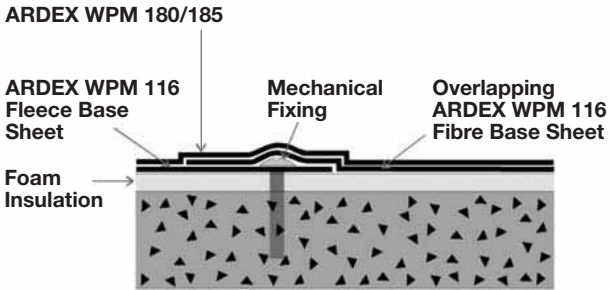

**MECHANICAL FIXING OVER FOAM
3 LAYER SYSTEM**

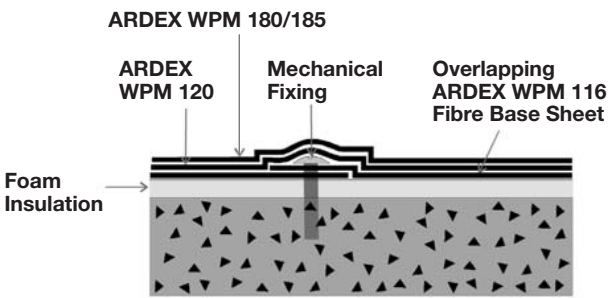

ROOF EDGE – MECHANICALLY FIXED

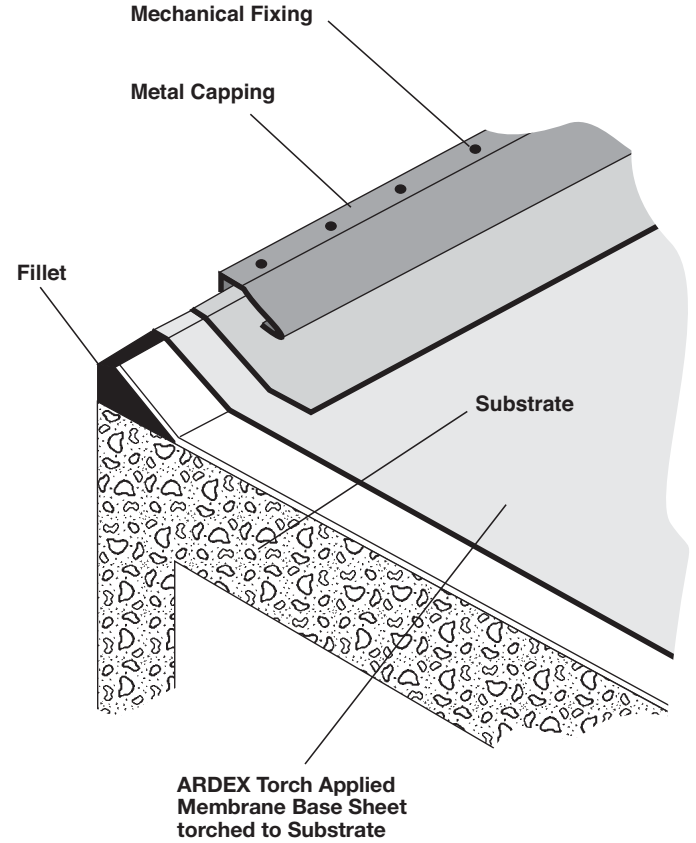

TYPICAL OUTLET DETAIL

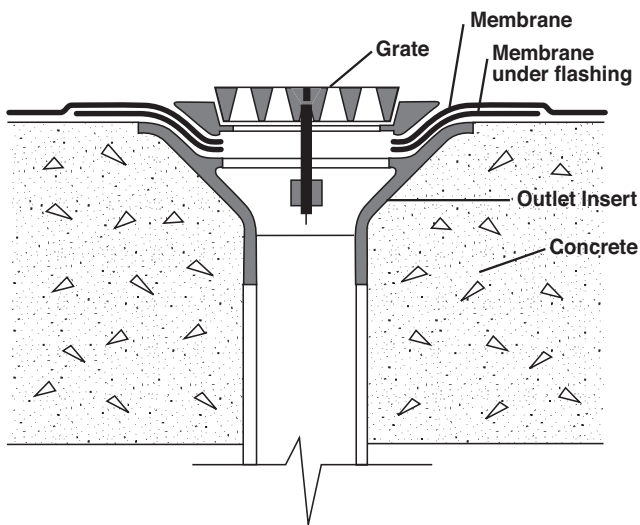

ROOF EDGE ON LOAD BEARING WALL

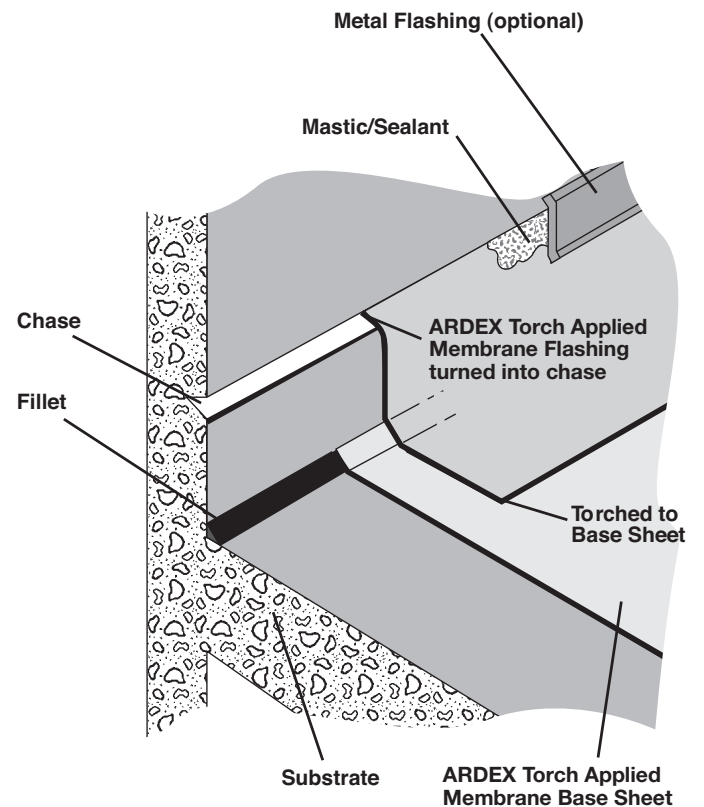

ARDEX Torch Applied Membrane

Installation Details

OUTSIDE CORNER

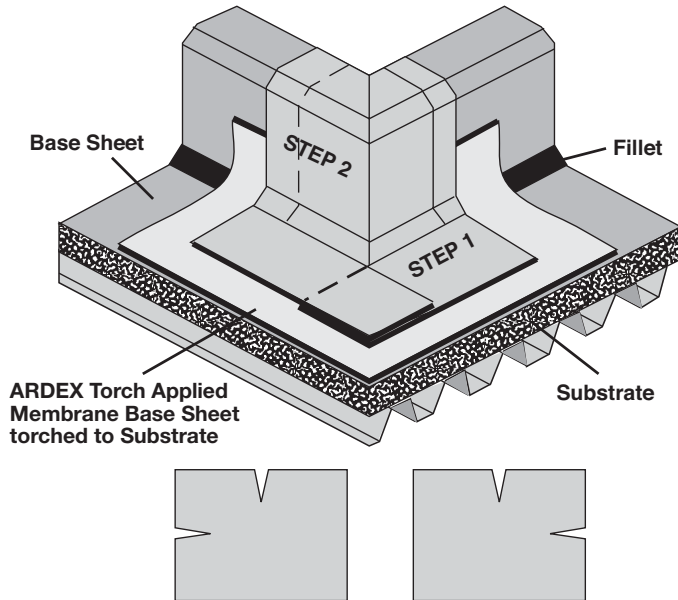

ONE WAY VENT INSTALLATION

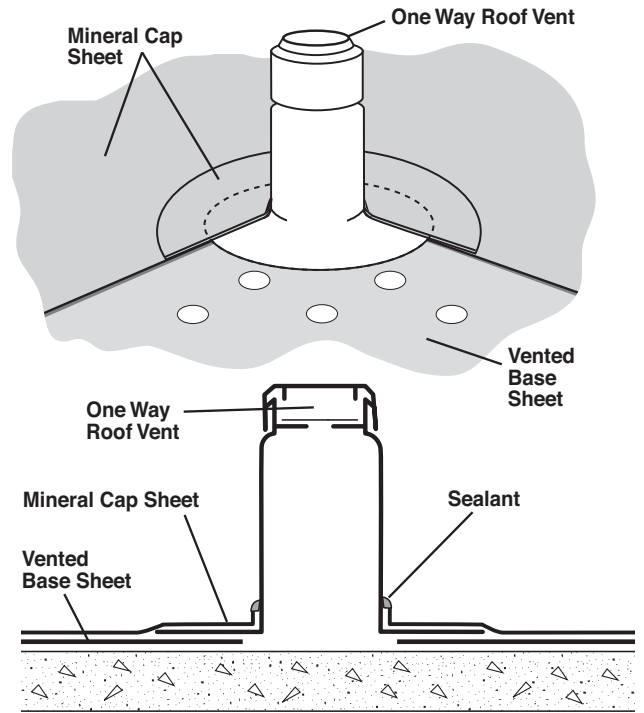

PIPE FLASHING

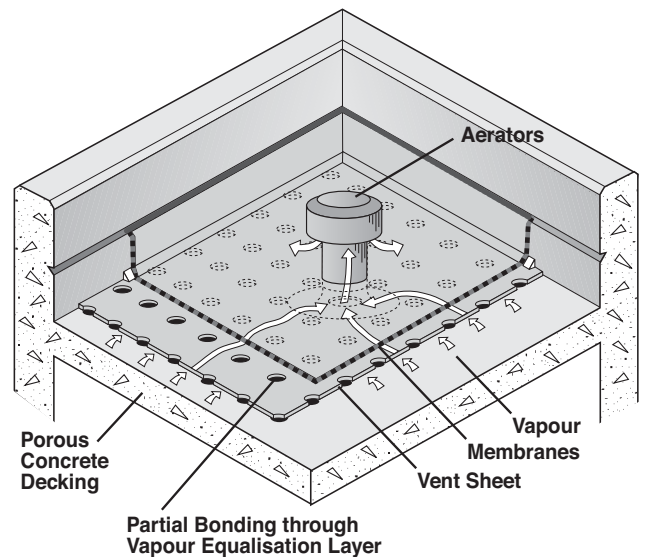
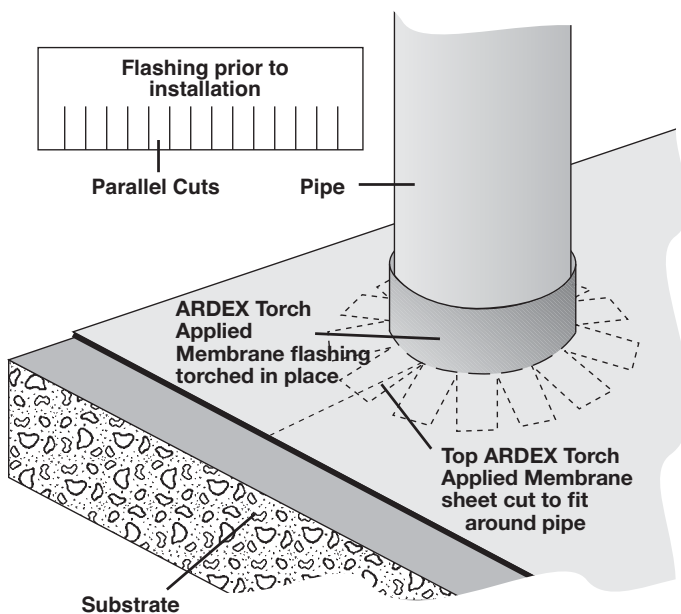

SKYLIGHT FLASHING

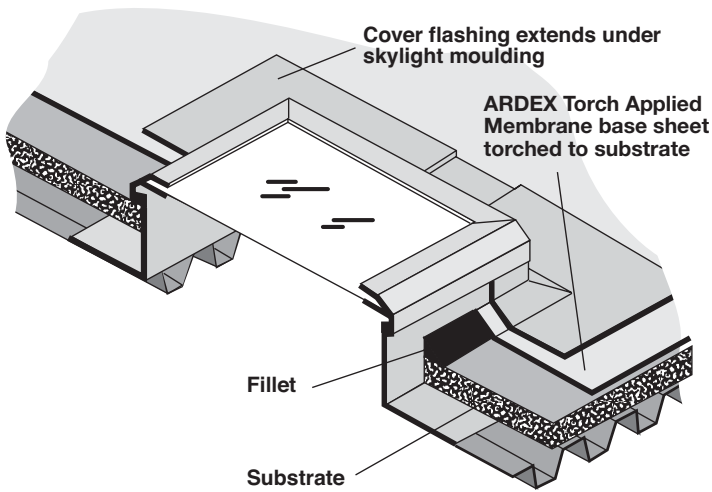

IRMA ROOF OVERFLOW

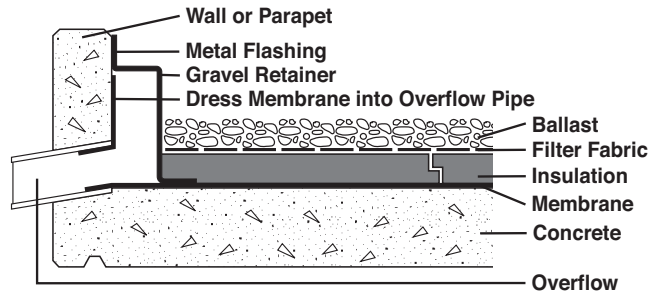

IRMA ROOF OUTLET & GRAVEL RETAINER

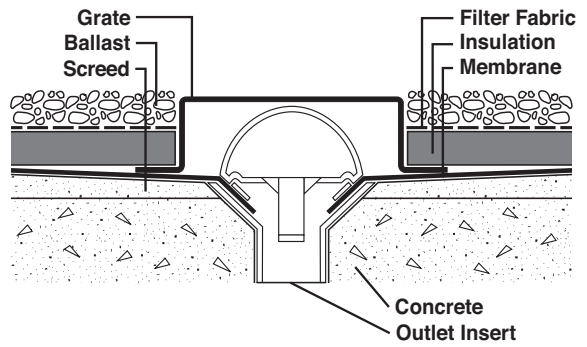

TYPICAL IRMA ROOF DETAIL

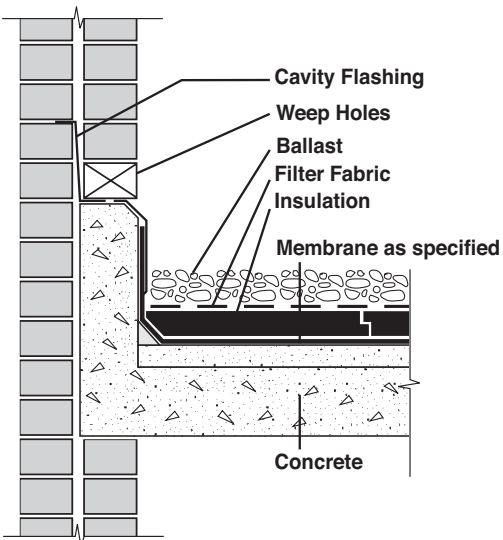
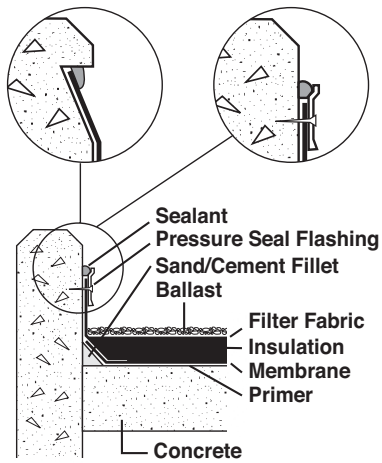

ARDEX Torch Applied Membrane

Installation Details

TYPICAL IRMA ROOF DETAIL

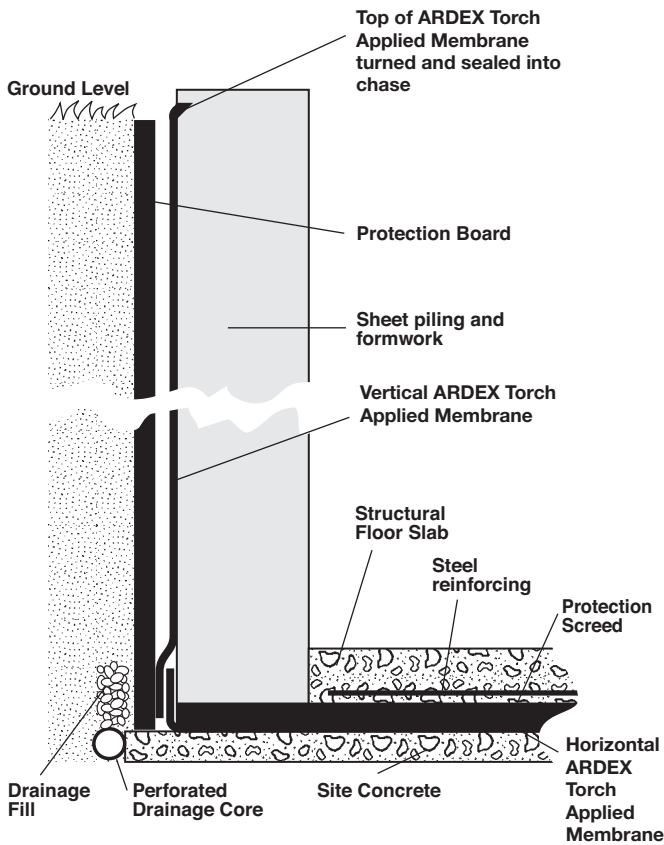

Important Note:

Drainage core should always be positioned lower than the horizontal membrane

BELOW GRADE DETAIL

Preferred Option

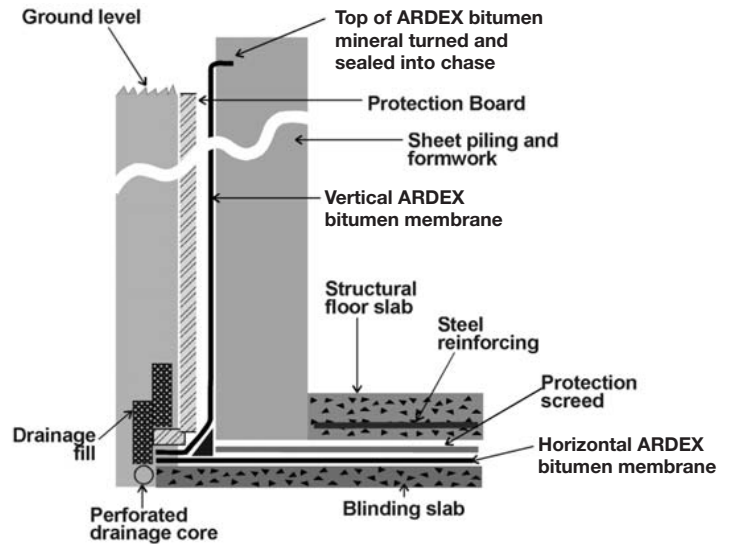

Alternate Option

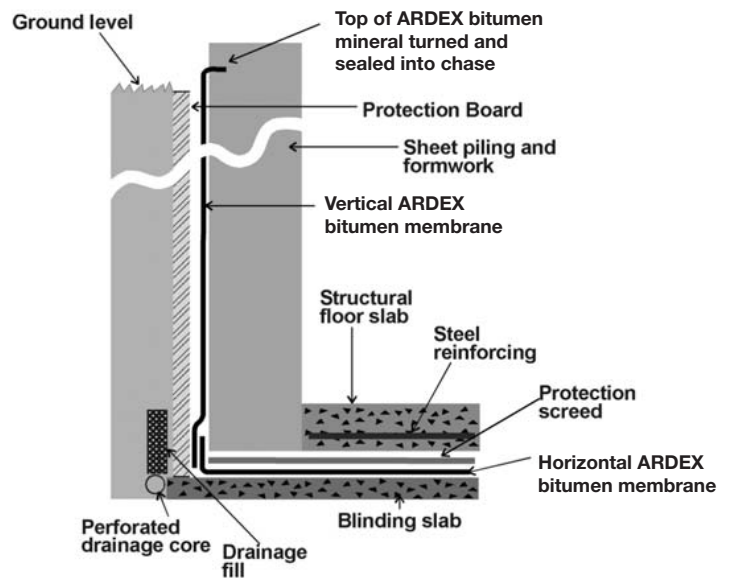



ARDEX WPM 115

(Shelterbit Vented Base Sheet)

0.8mm APP Bitumen Vented Base Sheet

Specially designed perforated base sheet for use in a multi-layer waterproofing system

Eliminates bubbles and blisters forming underneath the waterproofing layer

ARDEX Australia Pty Ltd
20 Powers Road
Seven Hills NSW 2147
Tel: (02) 9851 9199
Fax: (02) 9674 5621
Email: techinfo@ardexaustralia.com
Internet: www.ardex.com

ARDEX New Zealand Ltd
32 Lane St, Woolston
Christchurch, New Zealand
Tel: (03) 384 3029
Fax: (03) 384 9779
Email: techinfo@ardexaustralia.com
Internet: www.ardex.com

ARDEX WPM 115

(Shelterbit Vented Base Sheet)

0.8mm APP Bitumen Vented Base Sheet

PRODUCT DESCRIPTION

ARDEX WPM 115 (Shelterbit Vented Base Sheet) is an A.P.P (Atactic Polypropylene Plastomeric) type modified bitumen membrane vented base sheet, consisting of a specially formulated bituminous compound of distilled asphalt modified with selected high grade visco-elastic polymers.

A protective heat sensitive polythene film covers both surfaces of the vented Base Sheet.

FEATURES AND BENEFITS

ARDEX WPM 115:

- Is a specially designed perforated base-sheet for use in a multi-layer waterproofing system.
- Virtually eliminates bubbles and blisters forming underneath the waterproofing layer.
- Allows vapour permeating through the deck to diffuse underneath the waterproofing where, ideally, aerators will be installed to allow the vapour to escape to atmosphere.
- Eliminates the creation of stresses in the waterproofing layers thus greatly reducing failures in the waterproofing caused by deck movements.
- Is the ideal solution for controlled, partially attached first layer in a multi-layer system.

INSTALLATION

The application of ARDEX Torch Applied Membranes should be carried out by an accredited applicator.

Installation shall be strictly in accordance with the manufacturer's recommendations.

Acceptable substrates to which ARDEX Torch Applied Membranes is to be installed must be properly prepared prior to membrane installation.

ARDEX Torch Applied Membranes may be used in various combinations to produce a variety of specifications tailored to suit the individual waterproofing need.

The exact specification will depend on functional and economic requirements. Advice should be sought for suitable specification from ARDEX.

SAFETY PRECAUTIONS

ARDEX WPM 115 is hazardous; non-dangerous goods. However during installation exercise caution when working with open flame. Examine all surfaces to which the flame has been applied for smouldering or burning conditions.

Do not use open flame on or near highly combustible materials. Follow all local fire codes.

STORAGE

All rolls of ARDEX Torch Applied Membranes should be stored in a covered area protected against sunlight and UV radiation. Rolls should be stored in a vertical position on a smooth floor so as not to damage the edges.

PACKAGING

Roll size: 1m x 20m

Roll weight: Approximately 20kg

Rolls per pallet: 25

TECHNICAL DATA

The Technical Data shown below are the average results of the Tests, Measurements and Trials, carried out on ARDEX WPM 115.

Characteristics	Standard	Units	Nom.
Length	UNI EN 1848-1	m	20
Width	UNI EN 1848-1	m	1.0
Thickness	UNI EN 1849-1	mm	0.8
Hole Diam.		mm	40
Number of Holes		per m ²	119
Heat Stability	UNI EN 1110	°C	110
Cold Flexibility	UNI EN 1109	°C	-5
Tensile strength	UNI EN 12311-1		
Ultimate Longitudinal		N/5cm	310
Ultimate Transverse		N/5cm	205
Elongation at Break	UNI EN 12311-1		
Longitudinal		%	2
Transverse		%	2
Tear resistance	UNI EN 12310-1		
Longitudinal		N	70
Transverse		N	80
Reinforcement	Glass Fibre	g.s.m.	60
Surface finishes	Lower ¹	torch film	
	Top ²	torch film	

Note 1) Lower surface; the surface which is applied to the structure being waterproofed.

Note 2) Top surface; exposed to underside of covering membrane.

All tests have been carried out to UEATC, to tolerances as per European Directive.

DISCLAIMER

The technical details, recommendations and other information contained in this data sheet are given in good faith and represent the best of our knowledge and experience at the time of printing. It is your responsibility to ensure that our products are used and handled correctly and in accordance with any applicable Australian Standard, our instructions and recommendations and only for the uses they are intended. We also reserve the right to update information without prior notice to you to reflect our ongoing research and development program.

Country specific recommendations, depending on local standards, codes of practice, building regulations or industry guidelines, may effect specific installation recommendations.

The supply of our products and services is also subject to certain terms, warranties and exclusions, which may have already been disclosed to you in prior dealings or are otherwise available to you on request. You should make yourself familiar with them.

ARDEX Australia Pty Ltd

New South Wales	Ph (02) 9851 9100	Fax (02) 9838 7970
Queensland	Ph (07) 3817 6000	Fax (07) 3881 3188
Victoria/Tasmania	Ph (03) 9308 9255	Fax (03) 9308 9332
South Australia	Ph (08) 8268 2511	Fax (08) 8345 3207
Western Australia	Ph (08) 9256 8600	Fax (08) 9455 1227

ARDEX New Zealand Ltd

Auckland	Ph (09) 5800 005	Fax (09) 5799 963
Wellington	Ph (04) 5685 949	Fax (04) 5686 376
Christchurch	Ph (03) 3843 029	Fax (03) 3849 779

Technical Services Toll Free: 1800 224 070

Date: July 2007



ARDEX WPM 116

(Shelterbit Fibre Back Base Sheet)

2.7mm APP Bitumen Fibre Backed Base Sheet

Excellent elongation – 60% at break

Cold Flexibility to -5°C

Excellent resistance to pollutants

ARDEX Australia Pty Ltd
20 Powers Road
Seven Hills NSW 2147
Tel: (02) 9851 9199
Fax: (02) 9674 5621
Email: techinfo@ardexaustralia.com
Internet: www.ardex.com

ARDEX New Zealand Ltd
32 Lane St, Woolston
Christchurch, New Zealand
Tel: (03) 384 3029
Fax: (03) 384 9779
Email: techinfo@ardexaustralia.com
Internet: www.ardex.com

ARDEX WPM 116

(Shelterbit Fibre Back Base Sheet)

2.7mm APP Bitumen Fibre Backed Base Sheet

PRODUCT DESCRIPTION

ARDEX WPM 116 (Shelterbit F.B. Base Sheet) is an A.P.P. (Atactic Polypropylene Plastomeric) type modified bitumen membrane slip or base sheet, consisting of a specially formulated bituminous compound of distilled asphalt modified with selected high grade visco-elastic polymers. The product is reinforced with a combination of fibreglass and non-woven polyester.

ARDEX WPM 116 top surface is embossed and protected by a heat sensitive polythene film. This type of finish for the top surface has been chosen for two specific purposes.

1. To act as a temperature gauge during application. When the film melts it shows that the compound is at the correct temperature.
2. The embossing is to allow the gases to rapidly escape when heated to its correct installation temperature avoiding possible problems of bubbling and blistering, due to gases being trapped between the slip or base sheet and the membrane subsequently applied on top.

The lower surface of the slip or base sheet is an uncoated non-woven polyester matt.

PHYSICAL AND CHEMICAL PROPERTIES

A.P.P. modified compound

- Excellent elongation
- Cold flexibility -5°C
- Excellent resistance to pollutants
- Good elastic memory
- Good mechanical characteristics
- Good dimensional stability
- Good puncture resistance
- Will not decay
- Good elongation

USES

ARDEX WPM 116 is always installed as a base sheet in multi-layer systems either loose laid mechanically fastened (using large headed roofing fasteners under overlap area) or fully adhered with ARDEX WPM 245 Adhesive (Shelterbit Fibre Back Adhesive).

ARDEX WPM 116 has been specifically designed for applications to heat sensitive substrates such as wooden decks or thermal insulation.

Also can be installed as a base-layer on rough or un-even concrete decks.

Overlaps are not normally torched sealed unless ARDEX WPM 116 is to be used as a vapour control layer or as a secondary-waterproofing layer.

INSTALLATION

The application of ARDEX WPM 116 should be carried out by an accredited applicator.

Installation shall be strictly in accordance with the manufacturer's recommendations.

Acceptable substrates to which ARDEX WPM 116 is to be installed must be properly prepared prior to membrane installation.

ARDEX WPM 116 may be used in various combinations to produce a variety of specifications tailored to suit the individual waterproofing need.

The exact specification will depend on functional and economic requirements. Advice should be sought for suitable specifications from ARDEX Australia Pty Ltd.

SAFETY PRECAUTIONS

ARDEX WPM 116 is hazardous; non-dangerous goods.

During installation, exercise caution when working with open flame. Examine all surfaces to which the flame has been applied for smouldering or burning conditions.

Do not use open flame on or near highly combustible materials such as wet adhesive. Follow all local fire codes.

STORAGE

All rolls of ARDEX WPM 116 should be stored in a covered area protected against sunlight and UV radiation. Rolls should be stored in a vertical position on a smooth floor so as not to damage the edges.

PACKAGING

Roll size: 1.05m x 10m (Fleece is 1.0m wide leaving 50mm selvedge for lap bonding).

Roll weight: Approximately 30kg.

Rolls per pallet: 30

TECHNICAL DATA

The Technical Data shown below are the average results of the Tests, Measurements and Trials, carried out on ARDEX WPM 116.

Characteristics	Standard	Units	Nom.
Length	UNI EN 1848-1	m	10
Width	UNI EN 1848-1	m	1.0
Thickness	UNI EN 1849-1	mm	2.7
Aeric Mass	UNI EN 1849-1	kg/m ²	3
Heat Stability	UNI EN 1110	°C	110
Cold Flexibility	UNI EN 1109	°C	-5
Tensile strength	UNI EN 12311-1		
Ultimate Longitudinal		N/5cm	600
Ultimate Transverse		N/5cm	350
Elongation at Break	UNI EN 12311-1		
Longitudinal		%	60
Transverse		%	60
Tear resistance	UNI EN 12310-1		
Longitudinal		N	100
Transverse		N	100
Reinforcement	Glass Fibre	g.s.m.	50
Surface finishes	Lower ¹	polyester	
	Top ²	torch film	

Note 1) Lower surface; the surface which is applied to the structure being waterproofed.

Note 2) Top surface; exposed to underside of covering membrane.

All tests have been carried out to UEATC, to tolerances as per European Directive.

DISCLAIMER

The technical details, recommendations and other information contained in this data sheet are given in good faith and represent the best of our knowledge and experience at the time of printing. It is your responsibility to ensure that our products are used and handled correctly and in accordance with any applicable Australian Standard, our instructions and recommendations and only for the uses they are intended. We also reserve the right to update information without prior notice to you to reflect our ongoing research and development program.

Country specific recommendations, depending on local standards, codes of practice, building regulations or industry guidelines, may effect specific installation recommendations.

The supply of our products and services is also subject to certain terms, warranties and exclusions, which may have already been disclosed to you in prior dealings or are otherwise available to you on request. You should make yourself familiar with them.

ARDEX Australia Pty Ltd

New South Wales	Ph (02) 9851 9100	Fax (02) 9838 7970
Queensland	Ph (07) 3817 6000	Fax (07) 3881 3188
Victoria/Tasmania	Ph (03) 9308 9255	Fax (03) 9308 9332
South Australia	Ph (08) 8268 2511	Fax (08) 8345 3207
Western Australia	Ph (08) 9256 8600	Fax (08) 9455 1227

ARDEX New Zealand Ltd

Auckland	Ph (09) 5800 005	Fax (09) 5799 963
Wellington	Ph (04) 5685 949	Fax (04) 5686 376
Christchurch	Ph (03) 3843 029	Fax (03) 3849 779

Technical Services Toll Free: 1800 224 070

Date: July 2007



ARDEX WPM 120

(Shelterbit 120 Membrane)

2.5mm Combined Reinforced APP Bitumen

ARDEX Australia Pty Ltd
20 Powers Road
Seven Hills NSW 2147
Tel: (02) 9851 9199
Fax: (02) 9674 5621
Email: techinfo@ardexaustralia.com
Internet: www.ardex.com

ARDEX New Zealand Ltd
32 Lane St, Woolston
Christchurch, New Zealand
Tel: (03) 384 3029
Fax: (03) 384 9779
Email: techinfo@ardexaustralia.com
Internet: www.ardex.com

ARDEX WPM 120

(Shelterbit 120 Membrane)

2.5mm Combined Reinforced APP Bitumen

PRODUCT DESCRIPTION

ARDEX WPM 120 (Shelterbit Fibrepol 120) is an A.P.P. (Atactic Polypropylene Plastomeric) type modified bitumen membrane, consisting of a specially formulated bituminous compound of distilled asphalt modified with selected high grade visco-elastic polymers and reinforced with a combined reinforcement carrier.

ARDEX WPM 120 is coated with either a sanded or talc top surface finish, while the bottom surface is embossed and protected by a heat sensitive polythene film. This type of finish for the lower surface has been chosen for two specific purposes.

1. To act as a temperature gauge during application. When the film melts it shows that the compound is at the correct temperature.
2. The embossing is to allow the gases to rapidly escape when heated to its correct installation temperature avoiding possible problems of bubbling and blistering.

FEATURES AND BENEFITS

A.P.P. modified compound

- Excellent cold flexibility to -5°C
- Excellent elongation
- Heat welded laps provide homogenous joint
- Prefabricated membrane
- Good elastic memory

Combined reinforcement carrier

- High mechanical characteristics
- High puncture resistance
- Will not decay

USES

ARDEX WPM 120 is used as a base and or mid layer in multi-layer tanking membrane systems in horizontal or vertical applications, also for waterproofing balconies, terraces and roofs. ARDEX WPM 120 membrane is a sandwich membrane and must be protected from UV.

INSTALLATION

The application of ARDEX WPM 120 should be carried out by an accredited applicator.

Installation shall be strictly in accordance with the manufacturer's recommendations.

Acceptable substrates to which ARDEX WPM 120 is installed must be properly prepared prior to membranes installation.

All surfaces must be dry, clean, smooth, free of sharp edges, loose or foreign materials, oil, grease and other materials which may damage the membrane.

Prior to the application of ARDEX WPM 120 the base substrate surfaces should be primed with ARDEX WPM 240 (Shelterbit primer). Coverage of primer will depend on the porosity of the substrate.

ARDEX WPM 120 is normally fully bonded to the prepared substrate with side laps of 100mm and end laps of 150mm.

Overlaps shall be sealed by torch.

ARDEX WPM 120 may be used in various combinations to produce a variety of specifications tailored to suit the individual waterproofing need.

The exact specification will depend on functional and economic requirements. Advice should be sought for suitable specifications from ARDEX Australia Pty Ltd.

SAFETY PRECAUTIONS

ARDEX WPM 120 is hazardous; non-dangerous goods.

However during installation exercise caution when working with open flame. Examine all surfaces to which the flame has been applied for smouldering or burning conditions.

Do not use open flame on or near highly combustible materials. Follow all local fire codes.

STORAGE

All rolls of ARDEX WPM 120 should be stored in a covered area protected against sunlight and UV radiation. Rolls should be stored in a vertical position on a smooth floor so as not to damage the edges.

PACKAGING

Roll size: 1m x 15m

Roll weight: 43.5kg

Rolls per pallet: 23

TECHNICAL DATA

The Technical Data shown below are the average results of the Tests, Measurements and Trials, carried out on ARDEX WPM 120 Waterproofing Membrane.

Characteristics	Standard	Units	Nom.
Length	UNI EN 1848-1	m	15
Width	UNI EN 1848-1	m	1.0
Thickness	UNI EN 1849-1	mm	2.5
Aeric Mass	UNI EN 1849-1	kg/m ²	2.9
Heat Stability	UNI EN 1110	°C	110
Cold Flexibility	UNI EN 1109	°C	-5
Tensile strength	UNI EN 12311-1		
Ultimate Longitudinal		N/5cm	530
Ultimate Transverse		N/5cm	400
Elongation at Break	UNI EN 12311-1		
Longitudinal		%	35
Transverse		%	40
Tear resistance	UNI EN 12310-1		
Longitudinal		N	120
Transverse		N	120
Reinforcement	Combined	g.s.m.	120
Surface finishes	Lower ¹ Top ²	torch film sand	

Note 1) Lower surface; the surface which is applied to the structure being waterproofed.

Note 2) Top surface; exposed to underside of covering membrane.

All tests have been carried out to UEATC, to tolerances as per European Directive.

DISCLAIMER

The technical details, recommendations and other information contained in this data sheet are given in good faith and represent the best of our knowledge and experience at the time of printing. It is your responsibility to ensure that our products are used and handled correctly and in accordance with any applicable Australian Standard, our instructions and recommendations and only for the uses they are intended. We also reserve the right to update information without prior notice to you to reflect our ongoing research and development program.

Country specific recommendations, depending on local standards, codes of practice, building regulations or industry guidelines, may effect specific installation recommendations.

The supply of our products and services is also subject to certain terms, warranties and exclusions, which may have already been disclosed to you in prior dealings or are otherwise available to you on request. You should make yourself familiar with them.

ARDEX Australia Pty Ltd

New South Wales	Ph (02) 9851 9100	Fax (02) 9838 7970
Queensland	Ph (07) 3817 6000	Fax (07) 3881 3188
Victoria/Tasmania	Ph (03) 9308 9255	Fax (03) 9308 9332
South Australia	Ph (08) 8268 2511	Fax (08) 8345 3207
Western Australia	Ph (08) 9256 8600	Fax (08) 9455 1227

ARDEX New Zealand Ltd

Auckland	Ph (09) 5800 005	Fax (09) 5799 963
Wellington	Ph (04) 5685 949	Fax (04) 5686 376
Christchurch	Ph (03) 3843 029	Fax (03) 3849 779

Technical Services Toll Free: 1800 224 070

Date: July 2007



ARDEX WPM 122

(Shelterbit HD Bridge Membrane)

5.0mm Bridge & Deck APP Bitumen Membrane

Excellent cold flexibility -10°C

Resistance to aggressive chemicals

High puncture resistance

Used for bridge decks, car parks, road ways and viaducts

ARDEX Australia Pty Ltd
20 Powers Road
Seven Hills NSW 2147
Tel: (02) 9851 9199
Fax: (02) 9674 5621
Email: techinfo@ardexaustralia.com
Internet: www.ardex.com

ARDEX New Zealand Ltd
32 Lane St, Woolston
Christchurch, New Zealand
Tel: (03) 384 3029
Fax: (03) 384 9779
Email: techinfo@ardexaustralia.com
Internet: www.ardex.com

ARDEX WPM 122

(Shelterbit HD Bridge Membrane)

5.0mm Bridge & Deck APP Bitumen Membrane

PRODUCT DESCRIPTION

ARDEX WPM 122 is an A.P.P. (Atactic Polypropylene Plastomeric) type modified bitumen membrane, consisting of a specially formulated bituminous compound of distilled asphalt modified with selected high grade visco-elastic polymers and reinforced with a high quality non-woven 300g polyester carrier. ARDEX WPM 122 is coated with either a sanded or talc top surface finish, while the bottom surface is embossed and protected by a heat sensitive polythene film. This type of finish for the lower surface has been chosen for two specific purposes.

1. To act as a temperature gauge during application. When the film melts it shows that the compound is at the correct temperature.
2. The embossing is to allow the gases to rapidly escape when heated to its correct installation temperature avoiding possible problems of bubbling and blistering.

FEATURES AND BENEFITS

A.P.P. modified compound

- Excellent cold flexibility -10°C
- Excellent elongation
- Heat welded laps provide a homogenous joint
- Prefabricated membrane
- Good elastic memory
- Resistance to aggressive chemicals

Heavyweight non-woven polyester

- High mechanical characteristics
- High puncture resistance
- Good elongation
- Will not decay

USES

ARDEX WPM 122 has been specifically engineered using a heavy weight non-woven carrier for heavy-duty applications, particularly as a membrane under hot melt asphalt or bitumen.

Typical uses are:

- Bridge decks
- Car parks
- Road-ways
- Viaducts

ARDEX WPM 122 is a sandwich membrane and must be protected from UV radiation.

INSTALLATION

The application of ARDEX WPM 122 should be carried out by an accredited applicator.

Installation shall be strictly in accordance with the manufacturer's recommendations.

Acceptable substrates to which ARDEX WPM 122 systems are installed must be properly prepared prior to membrane installation.

All surfaces must be dry, clean, smooth, free of sharp edges, loose or foreign materials, oil, grease and other materials which may damage the membrane.

Prior to the application of ARDEX WPM 122 the surface should be primed with ARDEX WPM 240 (Shelterbit primer). Coverage of primer will depend on the porosity of the substrate.

ARDEX WPM 122 is fully bonded to the prepared substrate with side laps of 10cm and end laps of 15cm. Overlaps shall be sealed by torch.

ARDEX WPM 122 is used as a single layer membrane system which is normally installed prior to the installation of toppings, road base or hot melt asphalt or bitumen.

Application of toppings may be applied on completion. Road base may be installed directly to the membrane without an extra protection layer.

The asphalt should be applied as soon as possible after the ARDEX WPM 122 membrane has been installed. ARDEX recommend applying a minimum 50mm compacted overlay for carpark areas. The topping should be applied in two layers at a temperature of between 120-150°C.

The exact specification will depend on functional and economic requirements. Advice should be sought for suitable specifications from ARDEX Australia Pty Ltd.

SAFETY PRECAUTIONS

ARDEX WPM 122 is hazardous; non-dangerous goods. However during installation exercise caution when working with open flame. Examine all surfaces to which the flame has been applied for smouldering or burning conditions.

Do not use open flame on or near highly combustible materials. Follow all local fire codes.

STORAGE

All rolls of ARDEX WPM 122 should be stored in a covered area protected against sunlight and UV radiation. Rolls should be stored in a vertical position on a smooth floor so as not to damage the edges.

PACKAGING

Roll size: 1m x10m

Roll weight: 52kg

Rolls per pallet: 16

TECHNICAL DATA

The Technical Data shown below are the average results of the Tests, Measurements and Trials, carried out on ARDEX WPM 122 Waterproofing Membrane.

Characteristics	Standard	Units	Nom.
Length	UNI EN 1848-1	m	10
Width	UNI EN 1848-1	m	1.0
Thickness	UNI EN 1849-1	mm	5.0
Aeric Mass	UNI EN 1849-1	kg/m ²	5.2
Heat Stability	UNI EN 1110	°C	120
Cold Flexibility	UNI EN 1109	°C	-10
Tensile strength	UNI EN 12311-1		
Ultimate Longitudinal		N/5cm	1,150
Ultimate Transverse		N/5cm	950
Elongation at Break	UNI EN 12311-1		
Longitudinal		%	45
Transverse		%	50
Tear resistance	UNI EN 12310-1		
Longitudinal		N	200
Transverse		N	200
Reinforcement	polyester	g.s.m.	300
Surface finishes	Lower ¹	torch film	
	Top ²	sand	

Note 1) Lower surface; the surface which is applied to the structure being waterproofed.

Note 2) Top surface; exposed to underside of covering membrane.

All tests have been carried out to UEATC, to tolerances as per European Directive.

DISCLAIMER

The technical details, recommendations and other information contained in this data sheet are given in good faith and represent the best of our knowledge and experience at the time of printing. It is your responsibility to ensure that our products are used and handled correctly and in accordance with any applicable Australian Standard, our instructions and recommendations and only for the uses they are intended. We also reserve the right to update information without prior notice to you to reflect our ongoing research and development program.

Country specific recommendations, depending on local standards, codes of practice, building regulations or industry guidelines, may effect specific installation recommendations.

The supply of our products and services is also subject to certain terms, warranties and exclusions, which may have already been disclosed to you in prior dealings or are otherwise available to you on request. You should make yourself familiar with them.

ARDEX Australia Pty Ltd

New South Wales	Ph (02) 9851 9100	Fax (02) 9838 7970
Queensland	Ph (07) 3817 6000	Fax (07) 3881 3188
Victoria/Tasmania	Ph (03) 9308 9255	Fax (03) 9308 9332
South Australia	Ph (08) 8268 2511	Fax (08) 8345 3207
Western Australia	Ph (08) 9256 8600	Fax (08) 9455 1227

ARDEX New Zealand Ltd

Auckland	Ph (09) 5800 005	Fax (09) 5799 963
Wellington	Ph (04) 5685 949	Fax (04) 5686 376
Christchurch	Ph (03) 3843 029	Fax (03) 3849 779

Technical Services Toll Free: 1800 224 070

Date: July 2007



ARDEX WPM 126

(4.0mm Combined Reinforced APAO Bitumen Membrane)

Excellent cold flexibility to -35°C

Excellent elongation

Used as a high performance multi-layer tanking membrane, in horizontal and vertical applications

Also used for waterproofing balconies, terraces and roofs

ARDEX Australia Pty Ltd
20 Powers Road
Seven Hills NSW 2147
Tel: (02) 9851 9199
Fax: (02) 9674 5621
Email: techinfo@ardexaustralia.com
Internet: www.ardex.com

ARDEX New Zealand Ltd
32 Lane St, Woolston
Christchurch, New Zealand
Tel: (03) 384 3029
Fax: (03) 384 9779
Email: techinfo@ardexaustralia.com
Internet: www.ardex.com

ARDEX WPM 126

4.0mm Combined Reinforced APAO Bitumen Membrane

PRODUCT DESCRIPTION

ARDEX WPM 126 is an APAO (Amorphous Poly Alpha Olefin) plastomeric type modified bitumen membrane, consisting of a specially formulated bituminous compound of distilled asphalt modified with selected high grade visco-elastic polymers and reinforced with a combined reinforcement (polyester and fibreglass).

ARDEX WPM 126 is coated with either a sanded or talc top surface finish, while the bottom surface is embossed and protected by a heat sensitive polythene film. This type of finish for the lower surface has been chosen for two specific purposes.

1. To act as a temperature gauge during application. When the film melts it shows that the compound is at the correct temperature.
2. The embossing is to allow the gases to rapidly escape when heated to its correct installation temperature avoiding possible problems of bubbling and blistering.

FEATURES AND BENEFITS

A.P.A.O. modified compound

- Excellent cold flexibility to -35°C
- Excellent Cold Stability & Thermal Ageing Properties
- Excellent elongation
- Heat welded laps provide homogenous joint
- Prefabricated membrane
- Good elastic memory

Combined reinforcement carrier

- High mechanical characteristics
- High puncture resistance
- Good elongation
- Will not decay

USES

ARDEX WPM 126 is used as a high performance multi-layer tanking membrane in horizontal or vertical applications, also for waterproofing balconies, terraces and roofs. This product is particularly suitable for extreme cold conditions. ARDEX ARDEX WPM 126 membrane is a sandwich membrane and must be protected from UV.

ARDEX WPM 126 is also available as a fibre backed membrane for bonding to substrates and in a slate mineral finish for exposed conditions.

INSTALLATION

The application of ARDEX WPM 126 should be carried out by an accredited applicator.

Installation shall be strictly in accordance with the manufacturer's recommendations.

Acceptable substrates to which ARDEX WPM 126 is to be installed must be properly prepared prior to membrane installation.

All surfaces must be dry, clean, smooth, free of sharp edges, loose or foreign materials, oil, grease and other materials which may damage the membrane.

Prior to the application of ARDEX WPM 126, base substrate surfaces should be primed with ARDEX WPM 240 (Shelterbit Primer). Coverage of primer will depend on the porosity of the substrate.

ARDEX WPM 126 is normally fully bonded to the prepared substrate with side laps of 100mm and end laps of 150mm. Overlaps shall be sealed by torch.

ARDEX WPM 126 may be used in various combinations to produce a variety of specifications tailored to suit the individual waterproofing need.

The exact specification will depend on functional and economic requirements. Advice should be sought for suitable specification from ARDEX Australia Pty Ltd.

SAFETY PRECAUTIONS

ARDEX WPM 126 is hazardous; non-dangerous goods.

However, during installation exercise caution when working with open flame. Examine all surfaces to which the flame has been applied for smoldering or burning conditions.

Do not use open flame on or near highly combustible materials. Follow all local fire codes.

STORAGE

All rolls of ARDEX WPM 126 should be stored in a covered area protected against sunlight and UV radiation. Rolls should be stored in a vertical position on a smooth floor so as not to damage the edges.

PACKAGING

Roll size: 1m x 10m

Roll weight: Approximately 40kg

Rolls per pallet: 20

TECHNICAL DATA

The Technical Data shown below are the average results of the Tests, Measurements and Trials, carried out on ARDEX WPM 126 Waterproofing Membrane.

Characteristics	Standard	Units	Nom.
Length	UNI EN 1848-1	m	10
Width	UNI EN 1848-1	m	1.0
Thickness	UNI EN 1849-1	mm	4.0
Aeric Mass	UNI EN 1849-1	kg/m ²	5.4
Heat Stability	UNI EN 1110	°C	140
Cold Flexibility	UNI EN 1109	°C	-35
Cold Flexibility after 6 months @ 70°C	UNI EN 1109	°C	-35
Dimensional Stability	EN 1107-1A		
Longitudinal		%	-0.3
Transverse		%	+0.3
Impermeability	UNI EN 1928	kPa	60
Tensile strength	UNI EN 12311-1		
Ultimate Longitudinal		N/5cm	900
Ultimate Transverse		N/5cm	650
Elongation at Break	UNI EN 12311-1		
Longitudinal		%	45
Transverse		%	45
Tear resistance	UNI EN 12310-1		
Longitudinal		N	180
Transverse		N	180
Reinforcement	Combined	g.s.m.	180
Surface finishes	Lower ¹	torch film	
	Top ²	sand	

Note 1) Lower surface; the surface which is applied to the structure being waterproofed.

Note 2) Top surface; exposed to underside of covering membrane.

All tests have been carried out to UEATC, to tolerances as per European Directive.

DISCLAIMER

The technical details, recommendations and other information contained in this data sheet are given in good faith and represent the best of our knowledge and experience at the time of printing. It is your responsibility to ensure that our products are used and handled correctly and in accordance with any applicable Australian Standard, our instructions and recommendations and only for the uses they are intended. We also reserve the right to update information without prior notice to you to reflect our ongoing research and development program.

Country specific recommendations, depending on local standards, codes of practice, building regulations or industry guidelines, may effect specific installation recommendations.

The supply of our products and services is also subject to certain terms, warranties and exclusions, which may have already been disclosed to you in prior dealings or are otherwise available to you on request. You should make yourself familiar with them.

ARDEX Australia Pty Ltd

New South Wales	Ph (02) 9851 9100	Fax (02) 9838 7970
Queensland	Ph (07) 3817 6000	Fax (07) 3881 3188
Victoria/Tasmania	Ph (03) 9308 9255	Fax (03) 9308 9332
South Australia	Ph (08) 8268 2511	Fax (08) 8345 3207
Western Australia	Ph (08) 9256 8600	Fax (08) 9455 1227

ARDEX New Zealand Ltd

Auckland	Ph (09) 5800 005	Fax (09) 5799 963
Wellington	Ph (04) 5685 949	Fax (04) 5686 376
Christchurch	Ph (03) 3843 029	Fax (03) 3849 779

Technical Services Toll Free: 1800 224 070

Date: July 2007



ARDEX WPM 150

(Shelterbit 3/160 Membrane)

3.0mm Combined Reinforced APP Bitumen Membrane

Cold flexibility to -5°C

Excellent elongation

ARDEX Australia Pty Ltd
20 Powers Road
Seven Hills NSW 2147
Tel: (02) 9851 9199
Fax: (02) 9674 5621
Email: techinfo@ardexaustralia.com
Internet: www.ardex.com

ARDEX New Zealand Ltd
32 Lane St, Woolston
Christchurch, New Zealand
Tel: (03) 384 3029
Fax: (03) 384 9779
Email: techinfo@ardexaustralia.com
Internet: www.ardex.com

ARDEX WPM 150

(Shelterbit 3/160 Membrane)

3.0mm Combined Reinforced APP Bitumen Membrane

PRODUCT DESCRIPTION

ARDEX WPM 150 (Shelterbit 3/160) is an A.P.P. (Atactic Polypropylene Plastomeric) type modified bitumen membrane, consisting of a specially formulated bituminous compound of distilled asphalt modified with selected high grade visco-elastic polymers and reinforced with a polyester reinforcement.

ARDEX WPM 150 is coated with either a sanded or talc top surface finish, while the bottom surface is embossed and protected by a heat sensitive polythene film. This type of finish for the lower surface has been chosen for two specific purposes.

1. To act as a temperature gauge during application. When the film melts it shows that the compound is at the correct temperature.
2. The embossing is to allow the gases to rapidly escape when heated to its correct installation temperature avoiding possible problems of bubbling and blistering.

FEATURES AND BENEFITS

A.P.P. modified compound

- Excellent cold flexibility to -5°C
- Excellent elongation
- Heat welded laps provide homogenous joint
- Prefabricated membrane
- Good elastic memory

Combined reinforcement carrier

- High mechanical characteristics
- High puncture resistance
- Good elongation
- Will not decay

USES

ARDEX WPM 150 is used as a single layer or multi-layer tanking membrane in horizontal or vertical applications, also for waterproofing balconies, terraces and roofs. ARDEX WPM 150 membrane is a sandwich membrane and must be protected from UV radiation.

INSTALLATION

The application of ARDEX WPM 150 should be carried out by an accredited applicator.

Installation shall be strictly in accordance with the manufacturer's recommendations.

Acceptable substrates to which ARDEX WPM 150 systems are installed must be properly prepared prior to membrane installation.

All surfaces must be dry, clean, smooth, free of sharp edges, loose or foreign materials, oil, grease and other materials which may damage the membrane.

Prior to the application of ARDEX WPM 150 the base substrate surfaces should be primed with ARDEX WPM 240 (Shelterbit Primer). Coverage of primer will depend on the porosity of the substrate.

ARDEX WPM 150 is normally fully bonded to the prepared substrate with side laps of 75mm and end laps of 100mm. Overlaps shall be sealed by torch.

ARDEX WPM 150 may be used in various combinations to produce a variety of specifications tailored to suit the individual waterproofing need.

The exact specification will depend on functional and economic requirements. Advice should be sought for suitable specification from ARDEX Australia Pty Ltd.

SAFETY PRECAUTIONS

ARDEX WPM 150 is hazardous; non-dangerous goods.

However during installation exercise caution when working with open flame. Examine all surfaces to which the flame has been applied for smouldering or burning conditions.

Do not use open flame on or near highly combustible materials. Follow all local fire codes.

STORAGE

All rolls of ARDEX WPM 150 should be stored in a covered area protected against sunlight and UV radiation. Rolls should be stored in a vertical position on a smooth floor so as not to damage the edges.

PACKAGING

Roll size: 1m x 10m

Roll weight: Approximately 35kg

Rolls per pallet: 28

TECHNICAL DATA

The Technical Data shown below are the average results of the Tests, Measurements and Trials, carried out on ARDEX WPM 150 Waterproofing Membrane.

Characteristics	Standard	Units	Nom.
Length	UNI EN 1848-1	m	10
Width	UNI EN 1848-1	m	1.0
Thickness	UNI EN 1849-1	mm	3.0
Aeric Mass	UNI EN 1849-1	kg/m ²	3.5
Heat Stability	UNI EN 1110	°C	110
Cold Flexibility	UNI EN 1109	°C	-5
Tensile strength	UNI EN 12311-1		
Ultimate Longitudinal		N/5cm	870
Ultimate Transverse		N/5cm	560
Elongation at Break	UNI EN 12311-1		
Longitudinal		%	45
Transverse		%	45
Tear resistance	UNI EN 12310-1		
Longitudinal		N	130
Transverse		N	130
Reinforcement	Combined	g.s.m.	150
Surface finishes	Lower ¹ Top ²	torch film sand	

Note 1) Lower surface; the surface which is applied to the structure being waterproofed.

Note 2) Top surface; exposed to underside of covering membrane.

All tests have been carried out to UEATC, to tolerances as per European Directive.

DISCLAIMER

The technical details, recommendations and other information contained in this data sheet are given in good faith and represent the best of our knowledge and experience at the time of printing. It is your responsibility to ensure that our products are used and handled correctly and in accordance with any applicable Australian Standard, our instructions and recommendations and only for the uses they are intended. We also reserve the right to update information without prior notice to you to reflect our ongoing research and development program.

Country specific recommendations, depending on local standards, codes of practice, building regulations or industry guidelines, may effect specific installation recommendations.

The supply of our products and services is also subject to certain terms, warranties and exclusions, which may have already been disclosed to you in prior dealings or are otherwise available to you on request. You should make yourself familiar with them.

ARDEX Australia Pty Ltd

New South Wales	Ph (02) 9851 9100	Fax (02) 9838 7970
Queensland	Ph (07) 3817 6000	Fax (07) 3881 3188
Victoria/Tasmania	Ph (03) 9308 9255	Fax (03) 9308 9332
South Australia	Ph (08) 8268 2511	Fax (08) 8345 3207
Western Australia	Ph (08) 9256 8600	Fax (08) 9455 1227

ARDEX New Zealand Ltd

Auckland	Ph (09) 5800 005	Fax (09) 5799 963
Wellington	Ph (04) 5685 949	Fax (04) 5686 376
Christchurch	Ph (03) 3843 029	Fax (03) 3849 779

Technical Services Toll Free: 1800 224 070

Date: July 2007



ARDEX WPM 180

(Shelterbit 180 Membrane)

3.5mm Combined Reinforced APP Bitumen Membrane

Cold flexibility to -5°C

Excellent elongation

Prefabricated membrane

ARDEX Australia Pty Ltd
20 Powers Road
Seven Hills NSW 2147
Tel: (02) 9851 9199
Fax: (02) 9674 5621
Email: techinfo@ardexaustralia.com
Internet: www.ardex.com

ARDEX New Zealand Ltd
32 Lane St, Woolston
Christchurch, New Zealand
Tel: (03) 384 3029
Fax: (03) 384 9779
Email: techinfo@ardexaustralia.com
Internet: www.ardex.com

ARDEX WPM 180

(Shelterbit 180 Membrane)

3.5mm Combined Reinforced APP Bitumen Membrane

PRODUCT DESCRIPTION

ARDEX WPM 180 (Shelterbit Fibrepol 180) is an A.P.P. (Atactic Polypropylene Plastomeric) type modified bitumen membrane, consisting of a specially formulated bituminous compound of distilled asphalt modified with selected high grade visco-elastic polymers and reinforced with a combined reinforcement (polyester and fibreglass).

ARDEX WPM 180 is coated with either a sanded or talc top surface finish, while the bottom surface is embossed and protected by a heat sensitive polythene film. This type of finish for the lower surface has been chosen for two specific purposes.

1. To act as a temperature gauge during application. When the film melts it shows that the compound is at the correct temperature.
2. The embossing is to allow the gases to rapidly escape when heated to its correct installation temperature avoiding possible problems of bubbling and blistering.

FEATURES AND BENEFITS

A.P.P. modified compound

- Excellent cold flexibility to -5°C
- Excellent elongation
- Heat welded laps provide homogenous joint
- Prefabricated membrane
- Good elastic memory

Combined reinforcement carrier

- High mechanical characteristics
- High puncture resistance
- Good elongation
- Will not decay

USES

ARDEX WPM 180 is used as a single layer or multi-layer tanking membrane in horizontal or vertical applications, also for waterproofing balconies, terraces and roofs. ARDEX WPM 180 membrane is a sandwich membrane and must be protected from UV radiation.

INSTALLATION

The application of ARDEX WPM 180 should be carried out by an accredited applicator.

Installation shall be strictly in accordance with the manufacturer's recommendations.

Acceptable substrates to which ARDEX WPM 180 is to be installed must be properly prepared prior to membrane installation.

All surfaces must be dry, clean, smooth, free of sharp edges, loose or foreign materials, oil, grease and other materials which may damage the membrane.

Prior to the application of ARDEX WPM 180 base substrate surfaces should be primed with ARDEX WPM 240 (Shelterbit Primer). Coverage of primer will depend on the porosity of the substrate.

ARDEX WPM 180 is normally fully bonded to the prepared substrate with side laps of 75mm and end laps of 100mm. Overlaps shall be sealed by torch.

ARDEX WPM 180 may be used in various combinations to produce a variety of specifications tailored to suit the individual waterproofing need.

The exact specification will depend on functional and economic requirements. Advice should be sought for suitable specification from ARDEX Australia Pty Ltd.

SAFETY PRECAUTIONS

ARDEX WPM 180 is hazardous; non-dangerous goods.

However during installation exercise caution when working with open flame. Examine all surfaces to which the flame has been applied for smouldering or burning conditions.

Do not use open flame on or near highly combustible materials. Follow all local fire codes.

STORAGE

All rolls of ARDEX WPM 180 should be stored in a covered area protected against sunlight and UV radiation. Rolls should be stored in a vertical position on a smooth floor so as not to damage the edges.

PACKAGING

Roll size: 1m x 10m

Roll weight: Approximately 42kg

Rolls per pallet: 23

TECHNICAL DATA

The Technical Data shown below are the average results of the Tests, Measurements and Trials, carried out on ARDEX Shelterbit Waterproofing Membrane.

Characteristics	Standard	Units	Nom.
Length	UNI EN 1848-1	m	10
Width	UNI EN 1848-1	m	1.0
Thickness	UNI EN 1849-1	mm	3.5
Aeric Mass	UNI EN 1849-1	kg/m ²	4.2
Heat Stability	UNI EN 1110	°C	110
Cold Flexibility	UNI EN 1109	°C	-5
Tensile strength	UNI EN 12311-1		
Ultimate Longitudinal		N/5cm	720
Ultimate Transverse		N/5cm	420
Elongation at Break	UNI EN 12311-1		
Longitudinal		%	40
Transverse		%	45
Tear resistance	UNI EN 12310-1		
Longitudinal		N	130
Transverse		N	130
Reinforcement	Combined	g.s.m.	180
Surface finishes	Lower ¹ Top ²	torch film sand	

Note 1) Lower surface; the surface which is applied to the structure being waterproofed.

Note 2) Top surface; exposed to underside of covering membrane.

All tests have been carried out to UEATC, to tolerances as per European Directive.

DISCLAIMER

The technical details, recommendations and other information contained in this data sheet are given in good faith and represent the best of our knowledge and experience at the time of printing. It is your responsibility to ensure that our products are used and handled correctly and in accordance with any applicable Australian Standard, our instructions and recommendations and only for the uses they are intended. We also reserve the right to update information without prior notice to you to reflect our ongoing research and development program.

Country specific recommendations, depending on local standards, codes of practice, building regulations or industry guidelines, may effect specific installation recommendations.

The supply of our products and services is also subject to certain terms, warranties and exclusions, which may have already been disclosed to you in prior dealings or are otherwise available to you on request. You should make yourself familiar with them.

ARDEX Australia Pty Ltd

New South Wales	Ph (02) 9851 9100	Fax (02) 9838 7970
Queensland	Ph (07) 3817 6000	Fax (07) 3881 3188
Victoria/Tasmania	Ph (03) 9308 9255	Fax (03) 9308 9332
South Australia	Ph (08) 8268 2511	Fax (08) 8345 3207
Western Australia	Ph (08) 9256 8600	Fax (08) 9455 1227

ARDEX New Zealand Ltd

Auckland	Ph (09) 5800 005	Fax (09) 5799 963
Wellington	Ph (04) 5685 949	Fax (04) 5686 376
Christchurch	Ph (03) 3843 029	Fax (03) 3849 779

Technical Services Toll Free: 1800 224 070

Date: July 2007



ARDEX WPM 185

(Shelterbit Mineral Membrane)

4.5kg/m² Mineral Coated APP Bitumen Membrane

Excellent resistance to atmospheric agents

Resistant to chemical attacks

High puncture resistance

ARDEX Australia Pty Ltd
20 Powers Road
Seven Hills NSW 2147
Tel: (02) 9851 9199
Fax: (02) 9674 5621
Email: techinfo@ardexaustralia.com
Internet: www.ardex.com

ARDEX New Zealand Ltd
32 Lane St, Woolston
Christchurch, New Zealand
Tel: (03) 384 3029
Fax: (03) 384 9779
Email: techinfo@ardexaustralia.com
Internet: www.ardex.com

ARDEX WPM 185

(Shelterbit Mineral Membrane)

4.5kg/m² Mineral Coated APP Bitumen Membrane

PRODUCT DESCRIPTION

ARDEX WPM 185 (Shelterbit Mineral) is an A.P.P. (Atactic Polypropylene Plastomeric) type modified bitumen membrane, consisting of a specially formulated bituminous compound of distilled asphalt modified with selected high grade visco-elastic polymers and reinforced with a combined reinforcement (Polyester and Fibreglass).

ARDEX WPM 185 is coated with a slate mineral granule topping, while the bottom surface is embossed and protected by a heat sensitive polythene film. This type of finish for the lower surface has been chosen for two specific purposes.

1. To act as a temperature gauge during application. When the film melts it shows that the compound is at the correct temperature.
2. The embossing is to allow the gases to rapidly escape when heated to its correct installation temperature avoiding possible problems of bubbling and blistering.

FEATURES AND BENEFITS

- Positive vapour barrier
- Excellent resistance to atmospheric agents
- Cold flexibility -5°C
- Excellent elongation
- Resistant to chemical attacks
- Withstand thermal shocks
- Heat welded laps provide homogenous joint
- Prefabricated membrane
- High puncture resistance

USES

ARDEX WPM 185 is used as a cap layer in exposed membrane systems (allowing light foot traffic for maintenance).

ARDEX WPM 185 is available in slate grey, green and white.

INSTALLATION

The application of ARDEX WPM 185 should be carried out by an accredited applicator.

Installation shall be strictly in accordance with the manufacturer's recommendations.

Acceptable substrates to which ARDEX WPM 185 is to be installed must be properly prepared prior to membrane installation.

All surfaces must be dry, clean, smooth, free of sharp edges, loose or foreign materials, oil, grease and other materials which may damage the membrane.

ARDEX WPM 185 is normally installed in a multi-layer system incorporating ARDEX Bitumen membranes or base sheets.

ARDEX WPM 185 is fully bonded to plan or base layer. Overlaps are always torch-bonded with a width of 10cm.

The exact specification will depend on functional and economic requirements. Advice should be sought for suitable specification from ARDEX Australia Pty Ltd.

SAFETY PRECAUTIONS

ARDEX WPM 185 is hazardous; non-dangerous goods.

However during installation exercise caution when working with open flame. Examine all surfaces to which the flame has been applied for smouldering or burning conditions.

Do not use open flame on or near highly combustible materials. Follow all local fire codes.

STORAGE

All rolls of ARDEX WPM 185 should be stored in a covered area protected against sunlight and UV radiation. Rolls should be stored in a vertical position on a smooth floor so as not to damage the edges.

PACKAGING

Roll size: 1m x 10m

Roll weight: Approximately 45kg

Rolls per pallet: 20

TECHNICAL DATA

The Technical Data shown below are the average results of the Tests, Measurements and Trials, carried out on ARDEX WPM 185 Waterproofing Membrane.

Characteristics	Standard	Units	Nom.
Length	UNI EN 1848-1	m	10
Width	UNI EN 1848-1	m	1.0
Aeric Mass	UNI EN 1849-1	kg/m ²	4.5
Heat Stability	UNI EN 1110	°C	110
Cold Flexibility	UNI EN 1109	°C	-5
Tensile strength	UNI EN 12311-1		
Ultimate Longitudinal		N/5cm	720
Ultimate Transverse		N/5cm	420
Elongation at Break	UNI EN 12311-1		
Longitudinal		%	40
Transverse		%	45
Tear resistance	UNI EN 12310-1		
Longitudinal		N	130
Transverse		N	120
Reinforcement	Combined	g.s.m.	180
Surface finishes	Lower ¹	torch film	
	Top ²	slate chip	

Note 1) Lower surface; the surface which is applied to the structure being waterproofed.

Note 2) Top surface; exposed to underside of covering membrane.

All tests have been carried out to UEATC, to tolerances as per European Directive.

DISCLAIMER

The technical details, recommendations and other information contained in this data sheet are given in good faith and represent the best of our knowledge and experience at the time of printing. It is your responsibility to ensure that our products are used and handled correctly and in accordance with any applicable Australian Standard, our instructions and recommendations and only for the uses they are intended. We also reserve the right to update information without prior notice to you to reflect our ongoing research and development program.

Country specific recommendations, depending on local standards, codes of practice, building regulations or industry guidelines, may effect specific installation recommendations.

The supply of our products and services is also subject to certain terms, warranties and exclusions, which may have already been disclosed to you in prior dealings or are otherwise available to you on request. You should make yourself familiar with them.

ARDEX Australia Pty Ltd

New South Wales	Ph (02) 9851 9100	Fax (02) 9838 7970
Queensland	Ph (07) 3817 6000	Fax (07) 3881 3188
Victoria/Tasmania	Ph (03) 9308 9255	Fax (03) 9308 9332
South Australia	Ph (08) 8268 2511	Fax (08) 8345 3207
Western Australia	Ph (08) 9256 8600	Fax (08) 9455 1227

ARDEX New Zealand Ltd

Auckland	Ph (09) 5800 005	Fax (09) 5799 963
Wellington	Ph (04) 5685 949	Fax (04) 5686 376
Christchurch	Ph (03) 3843 029	Fax (03) 3849 779

Technical Services Toll Free: 1800 224 070

Date: July 2007



ARDEX WPM 186

(Shelterbit Garden Membrane)

3.5mm Garden APP Bitumen Membrane

Positive vapour barrier

Excellent resistance to pollutants and aging

Good elongation and flexibility

For waterproofing planter boxes, garden beds, roof gardens and flower beds

Contains root inhibitor – stops roots from plants damaging the membrane

ARDEX Australia Pty Ltd
20 Powers Road
Seven Hills NSW 2147
Tel: (02) 9851 9199
Fax: (02) 9674 5621
Email: techinfo@ardexaustralia.com
Internet: www.ardex.com

ARDEX New Zealand Ltd
32 Lane St, Woolston
Christchurch, New Zealand
Tel: (03) 384 3029
Fax: (03) 384 9779
Email: techinfo@ardexaustralia.com
Internet: www.ardex.com

ARDEX 186

(Shelterbit Garden Membrane)

3.5mm Garden APP Bitumen Membrane

PRODUCT DESCRIPTION

ARDEX WPM 186 (Shelterbit Garden) is an A.P.P. (Atactic Polypropylene Plastomeric) torch applied modified waterproofing membrane, consisting of a specially formulated bituminous compound of distilled asphalt modified with selected high grade visco-elastic polymers and reinforced with a high quality combined reinforcement (fibreglass and polyester) and treated with preventive chemical to stop roots from plants damaging the membrane.

ARDEX WPM 186 is coated with either a sanded or talc top surface finish, while the bottom surface is embossed and protected by a heat sensitive polythene film. This type of finish for the lower surface has been chosen for two specific purposes.

1. To act as a temperature gauge during application. When the film melts it shows that the compound is at the correct temperature.
2. The embossing is to allow the gases to rapidly escape when heated to its correct installation temperature avoiding possible problems of bubbling and blistering.

FEATURES AND BENEFITS

- Positive vapour barrier
- Excellent resistance to pollutants and aging
- Excellent cold flexibility -5°C
- Maintains shape stability at high temperatures
- High resistance to perforation
- Is rot-proof
- Resists root growth ingress into both the membrane and the laps
- Good elongation and flexibility
- Heat welded laps provide an homogenous joint

USES

ARDEX WPM 186 has been especially formulated for the waterproofing of:

- Planter boxes
- Garden beds
- Roof gardens
- Flower beds
- Green covered civil works etc

ARDEX WPM 186 may be installed in a one or multi-layer system incorporating normal bitumen membranes. ARDEX WPM 186 always being the top layer.

INSTALLATION

The application of ARDEX WPM 186 should be carried out by an accredited applicator.

Installation shall be strictly in accordance with the manufacturer's recommendations.

Acceptable substrates to which ARDEX WPM 186 is to be installed must be properly prepared prior to membrane installation.

All surfaces must be dry, clean, smooth, free of sharp edges, loose or foreign materials, oil, grease and other materials which may damage the membrane.

Prior to the application of ARDEX WPM 186 the surface should be primed with ARDEX WPM 240 (Shelterbit primer).

Coverage of primer will depend on the porosity of the substrate.

ARDEX WPM 186 is normally fully bonded to the prepared substrate with side laps of 10cm and end laps of 15cm overlaps shall be sealed by torch.

ARDEX WPM 186 may be used in various combinations to produce a variety of specifications tailored to suit the individual waterproofing need.

The exact specification will depend on functional and economic requirements. Advice should be sought for suitable specifications from ARDEX Australia Pty Ltd.

SAFETY PRECAUTIONS

ARDEX WPM 186 is hazardous; non-dangerous goods.

However during installation, exercise caution when working with open flame. Examine all surfaces to which the flame has been applied for smouldering or burning conditions.

Do not use open flame on or near highly combustible materials. Follow all local fire codes.

STORAGE

All rolls of ARDEX WPM 186 should be stored in a covered area protected against sunlight and UV radiation. Rolls should be stored in a vertical position on a smooth floor so as not to damage the edges.

PACKAGING

Roll size: 1m x 10m

Roll weight: Approximately 42kg

Rolls per pallet: 23

TECHNICAL DATA

The Technical Data shown below are the average results of the Tests, Measurements and Trials, carried out on ARDEX WPM 186 Waterproofing Membrane.

Characteristics	Standard	Units	Nom.
Length	UNI EN 1848-1	m	10
Width	UNI EN 1848-1	m	1.0
Thickness	UNI EN 1849-1	mm	3.5
Aeric Mass	UNI EN 1849-1	kg/m ²	4.2
Heat Stability	UNI EN 1110	°C	110
Cold Flexibility	UNI EN 1109	°C	-5
Tensile strength	UNI EN 12311-1		
Ultimate Longitudinal		N/5cm	720
Ultimate Transverse		N/5cm	420
Elongation at Break	UNI EN 12311-1		
Longitudinal		%	40
Transverse		%	45
Tear resistance	UNI EN 12310-1		
Longitudinal		N	130
Transverse		N	140
Reinforcement	Combined	g.s.m.	180
Surface finishes	Lower ¹ Top ²	torch film sand	

Note 1) Lower surface; the surface which is applied to the structure being waterproofed.

Note 2) Top surface; exposed to underside of covering membrane.

All tests have been carried out to UEATC, to tolerances as per European Directive.

DISCLAIMER

The technical details, recommendations and other information contained in this data sheet are given in good faith and represent the best of our knowledge and experience at the time of printing. It is your responsibility to ensure that our products are used and handled correctly and in accordance with any applicable Australian Standard, our instructions and recommendations and only for the uses they are intended. We also reserve the right to update information without prior notice to you to reflect our ongoing research and development program.

Country specific recommendations, depending on local standards, codes of practice, building regulations or industry guidelines, may effect specific installation recommendations.

The supply of our products and services is also subject to certain terms, warranties and exclusions, which may have already been disclosed to you in prior dealings or are otherwise available to you on request. You should make yourself familiar with them.

ARDEX Australia Pty Ltd

New South Wales	Ph (02) 9851 9100	Fax (02) 9838 7970
Queensland	Ph (07) 3817 6000	Fax (07) 3881 3188
Victoria/Tasmania	Ph (03) 9308 9255	Fax (03) 9308 9332
South Australia	Ph (08) 8268 2511	Fax (08) 8345 3207
Western Australia	Ph (08) 9256 8600	Fax (08) 9455 1227

ARDEX New Zealand Ltd

Auckland	Ph (09) 5800 005	Fax (09) 5799 963
Wellington	Ph (04) 5685 949	Fax (04) 5686 376
Christchurch	Ph (03) 3843 029	Fax (03) 3849 779

Technical Services Toll Free: 1800 224 070

Date: July 2007



ARDEX WPM 191

(Shelterbit SBS Cold Climate Membrane)

Provides an excellent waterproofing membrane for new and existing constructions

High flexibility during application at sub-zero temperature with no physical strains

Withstands thermal shocks

Proven performance in colder regions

ARDEX Australia Pty Ltd
20 Powers Road
Seven Hills NSW 2147
Tel: (02) 9851 9199
Fax: (02) 9674 5621
Email: techinfo@ardexaustralia.com
Internet: www.ardex.com

ARDEX New Zealand Ltd
32 Lane St, Woolston
Christchurch, New Zealand
Tel: (03) 384 3029
Fax: (03) 384 9779
Email: techinfo@ardexaustralia.com
Internet: www.ardex.com

ARDEX WPM 191

(Shelterbit SBS Cold Climate Membrane)

3.5mm SBS Bitumen Membrane

PRODUCT DESCRIPTION

ARDEX WPM 191 (Shelterbit Fibrepol SBS) is a high performance Styrene-Butadiene-Styrene (S.B.S.) rubber modified bitumen membrane, reinforced with a combined reinforcement (polyester and fibreglass).

The exceptional elongation properties of S.B.S. combined with the strength and dimensional stability of the reinforcing, provides an excellent waterproofing membrane for new and existing constructions.

ARDEX WPM 191 is coated with either a sanded or talc top surface finish, while the bottom surface is embossed and protected by a heat sensitive polythene film. This type of finish for the lower surface has been chosen for two specific purposes.

1. To act as a temperature gauge during application. When the film melts it shows that the compound is at the correct temperature.
2. The embossing is to allow the gases to rapidly escape when heated to its correct installation temperature avoiding possible problems of bubbling and blistering.

FEATURES AND BENEFITS

- Positive vapour barrier
- Excellent resistance to atmosphere agents
- High flexibility during application at sub-zero temperature with no physical strains
- High malleability
- Accommodates structural movements
- Resistant to chemical attacks
- Withstands thermal shocks
- Proven performance in colder regions
- Good elongation and flexibility

USES

ARDEX WPM 191 is used as a single layer or multi-layer tanking membrane in horizontal or vertical applications, also for waterproofing balconies, terraces and flat roofs. ARDEX WPM 191 membrane is a sandwich membrane and must be protected from UV radiation.

ARDEX WPM 191 is available in mineral finish for exposed roof areas.

INSTALLATION

The application of ARDEX WPM 191. should be carried out by an accredited applicator.

Installation shall be strictly in accordance with the manufacturers recommendations.

Acceptable substrates to which ARDEX WPM 191 is to be installed must be properly prepared prior to membrane installation.

All surfaces must be dry, clean, smooth, free of sharp edges, loose or foreign materials, oil, grease and other materials which may damage the membrane.

Prior to the application of ARDEX WPM 191 the surface may require priming with ARDEX WPM 240 (Shelterbit primer). Coverage of primer will depend on the porosity of the substrate.

ARDEX WPM 191 is normally fully bonded to the prepared substrate with side laps of 10cm and end laps of 15cm overlaps shall be sealed by torch.

ARDEX WPM 191 may be used in various combinations to produce a variety of specifications tailored to suit the individual waterproofing need.

The exact specification will depend on functional and economic requirements. Advice should be sought for suitable specifications from ARDEX Australia Pty Ltd.

SAFETY PRECAUTIONS

ARDEX WPM 191 is hazardous; non-dangerous goods.

However during installation exercise caution when working with open flame. Examine all surfaces to which the flame has been applied for smouldering or burning conditions.

Do not use open flame on or near highly combustible materials. Follow all local fire codes.

STORAGE

All rolls of ARDEX WPM 191 should be stored in a covered area protected against sunlight and UV radiation. Rolls should be stored in a vertical position on a smooth floor so as not to damage the edges.

PACKAGING

Roll size: 1m x 10m

Roll weight: Approximately 43kg

Rolls per pallet: 23

TECHNICAL DATA

The Technical Data shown below are the average results of the Tests, Measurements and Trials, carried out on ARDEX WPM 191 Waterproofing Membrane.

Characteristics	Standard	Units	Nom.
Length	UNI EN 1848-1	m	10
Width	UNI EN 1848-1	m	1.0
Thickness	UNI EN 1849-1	mm	3.5
Aeric Mass	UNI EN 1849-1	kg/m ²	4.3
Heat Stability	UNI EN 1110	°C	90
Cold Flexibility	UNI EN 1109	°C	-20
Tensile strength	UNI EN 12311-1		
Ultimate Longitudinal		N/5cm	720
Ultimate Transverse		N/5cm	420
Elongation at Break	UNI EN 12311-1		
Longitudinal		%	45
Transverse		%	45
Tear resistance	UNI EN 12310-1		
Longitudinal		N	160
Transverse		N	170
Reinforcement	combined	g.s.m.	180
Surface finishes	Lower ¹	torch film	
	Top ²	torch film	

Note 1) Lower surface; the surface which is applied to the structure being waterproofed.

Note 2) Top surface; exposed to underside of covering membrane.

All tests have been carried out to UEATC, to tolerances as per European Directive.

DISCLAIMER

The technical details, recommendations and other information contained in this data sheet are given in good faith and represent the best of our knowledge and experience at the time of printing. It is your responsibility to ensure that our products are used and handled correctly and in accordance with any applicable Australian Standard, our instructions and recommendations and only for the uses they are intended. We also reserve the right to update information without prior notice to you to reflect our ongoing research and development program.

Country specific recommendations, depending on local standards, codes of practice, building regulations or industry guidelines, may effect specific installation recommendations.

The supply of our products and services is also subject to certain terms, warranties and exclusions, which may have already been disclosed to you in prior dealings or are otherwise available to you on request. You should make yourself familiar with them.

ARDEX Australia Pty Ltd

New South Wales	Ph (02) 9851 9100	Fax (02) 9838 7970
Queensland	Ph (07) 3817 6000	Fax (07) 3881 3188
Victoria/Tasmania	Ph (03) 9308 9255	Fax (03) 9308 9332
South Australia	Ph (08) 8268 2511	Fax (08) 8345 3207
Western Australia	Ph (08) 9256 8600	Fax (08) 9455 1227

ARDEX New Zealand Ltd

Auckland	Ph (09) 5800 005	Fax (09) 5799 963
Wellington	Ph (04) 5685 949	Fax (04) 5686 376
Christchurch	Ph (03) 3843 029	Fax (03) 3849 779

Technical Services Toll Free: 1800 224 070

Date: July 2007



ARDEX WPM 3000X

(Shelterseal 3000X Membrane)

Cold application – installed without the use of open flames

Chemical resistance – highly resistant to acids, alkalis and other pollutants

Self sealing – membrane self seals on contact maintaining watertightness

Ideal for planter boxes, below ground applications and retaining walls

ARDEX Australia Pty Ltd
20 Powers Road
Seven Hills NSW 2147
Tel: (02) 9851 9199
Fax: (02) 9674 5621
Email: techinfo@ardexaustralia.com
Internet: www.ardex.com

ARDEX New Zealand Ltd
32 Lane St, Woolston
Christchurch, New Zealand
Tel: (03) 384 3029
Fax: (03) 384 9779
Email: techinfo@ardexaustralia.com
Internet: www.ardex.com

ARDEX WPM 3000X

(Shelterseal 3000X Membrane)

1.5mm SBS Self Adhesive Sheet Membrane

PRODUCT DESCRIPTION

ARDEX WPM 3000X (Shelterseal 3000X Self Adhesive Membrane) is a “peel and stick” bituminous/asphalt membrane protected by a cross laminated high-density polyethylene film.

ARDEX WPM 3000X is made from two structural components. Bitumen/asphalt compound modified with SBS and high tack resins

This special compound has been formulated to make the product easy to install. The membrane can be adjusted should it initially be placed in the wrong position, as the adhesive on the sheet achieves final adhesion only after a few minutes.

Protective film

This is hot-laminated to the bituminous/asphalt compound and gives the membrane its mechanical and physical characteristics, such as heat stability, shape, chemical resistance, etc.

FEATURES/BENEFITS

Cold Application

Installed without the use of open flames. Ideal for installation in restricted spaces.

Chemical resistance

The protective polymer film is highly resistant to acids, alkalis and other pollutants.

Flexibility and adaptability

This membrane will adapt easily to irregularly shaped surfaces, and will stretch without breaking or cracking.

Self sealing

The membrane self seals on contact maintaining its watertightness.

Constant thickness

The membrane is manufactured using high-tech machinery which constantly monitors its thickness, and ensures that the films and synthetic materials are manufactured to the highest specifications and quality control requirements.

ACCEPTABLE SUBSTRATES

- Concretes, renders and screeds
- Fibre cement sheets
- Structural or marine plywood
- Polystyrene blocks

For use over other substrates including existing membranes contact ARDEX.

TYPICAL APPLICATIONS

- Planter boxes
- Foundations
- Below-ground applications
- Retaining walls
- Balcony Decks under cement screeds or other compatible hard covering

BASIC APPLICATION INSTRUCTIONS

Surface Preparation

Surfaces to which the ARDEX WPM 3000X is to be installed must be properly prepared prior to installation. All surfaces must be clean, dry, smooth, free of sharp edges, loose or foreign materials, oil, grease, and other materials that may damage the membrane. If concrete has moisture on surface use gas torch to dry and warm before priming, apply one coat of ARDEX WPM 300 at a coverage rate of 3.0m² per L and allow to cure for at least 3 days prior to proceeding.

Priming

Prior to the application of the membrane all prepared surfaces (except polystyrene blocks) should be primed with ARDEX WPM 249 (Shelterseal Primer) at a rate of 5–6m² per litre and allowed to dry.

Application of ARDEX WPM 3000X

ARDEX WPM 3000X should always be applied from the lowest point to enable laps to shed water. All edge and end laps must be overlapped a minimum of 60mm. Internal and external corners shall be reinforced with an extra layer of membrane 300mm wide. All end laps and exposed edges should be sealed. On vertical surfaces the installation should start at the lowest point with the joints overlapping by at least 100mm, and formed so that they will shed water. All rolls of ARDEX WPM 3000X are marked with a 60mm line for overlapping.

Ensure that the membrane is properly adhered to the surface at perimeters or around penetrations.

On completion of the installation of ARDEX WPM 3000X it is recommended that a protection board be used before back filling to protect the membrane from damage.

Under no circumstances should the membrane be left exposed to UV light for long periods.

Two Layer DPC System

In critical areas a specifier may require a second layer of ARDEX WPM 3000X to be applied with laps staggered to the first layer.

ARDEX WPM 3000X should be installed by approved applicators, well trained in the application of self-adhesive membranes. Installation shall be strictly in accordance with ARDEX recommendations.

SAFETY PRECAUTIONS

ARDEX WPM 3000X is hazardous; non-dangerous goods. Wear eye/face protection. Use only in well ventilated areas. Keep rolls in well ventilated place. In case of contact with eyes, rinse with plenty of water and contact a doctor or Poisons Information Centre.

ARDEX WPM 249 is hazardous; non-dangerous goods. It is highly flammable, harmful if swallowed and irritating to the eyes and skin. Keep away from sources of ignition. No smoking. Keep container tightly closed and in a well ventilated place.

ADDITIONAL INFORMATION FOR ARDEX WPM 249 IS FOUND IN THE MATERIAL SAFETY DATA SHEET.

STORAGE

All rolls of ARDEX WPM 3000X, whether palletised or loose, should be stored in a cool covered area protected against sunlight and UV radiation. Rolls should be stored in a vertical position on a smooth floor so as not to damage the edges.

ADDITIONAL INFORMATION IS LISTED IN THE MATERIAL SAFETY DATA SHEET.

PACKAGING

Roll size: 1m x 20m

Roll weight: Approx 30kg.

Other products: ARDEX WPM 249 (Shelterseal Primer)
- 5 litres and 20 litres.

Rolls per pallet: 25

TECHNICAL PERFORMANCE DATA

Properties	Typical Values	Test Method
Thickness	1.5mm	UNI 8202
Weight	1.6kg	UNI 8202
Tensile strength long	4.35N/mm	ASTM D 638
Tensile strength trans	5.69N/mm	ASTM D 638
Longitudinal elongation of membrane	435%	ASTM D 638
Transverse elongation of membrane	380%	ASTM D 638
Tearing resistance long	83.01N	8202/9
Tearing resistance trans	73.74N	8202/9
Adhesion to primed concrete	4.9N/mm	ASTM D 1000
Adhesion to steel	5.8N/mm	ASTM D 1000
Puncture resistance	246N/65mm	ASTM E 154
Vapour transmission rate	0.3g/m/24hrs	ASTM E 96
Cold flexibility	-30°C	ASTM D 146
Environmental resistance	Conform	ASTM D 543

DISCLAIMER

The technical details, recommendations and other information contained in this data sheet are given in good faith and represent the best of our knowledge and experience at the time of printing. It is your responsibility to ensure that our products are used and handled correctly and in accordance with any applicable Australian Standard, our instructions and recommendations and only for the uses they are intended. We also reserve the right to update information without prior notice to you to reflect our ongoing research and development program.

Country specific recommendations, depending on local standards, codes of practice, building regulations or industry guidelines, may effect specific installation recommendations.

The supply of our products and services is also subject to certain terms, warranties and exclusions, which may have already been disclosed to you in prior dealings or are otherwise available to you on request. You should make yourself familiar with them.

ARDEX Australia Pty Ltd

New South Wales	Ph (02) 9851 9100	Fax (02) 9838 7970
Queensland	Ph (07) 3817 6000	Fax (07) 3881 3188
Victoria/Tasmania	Ph (03) 9308 9255	Fax (03) 9308 9332
South Australia	Ph (08) 8268 2511	Fax (08) 8345 3207
Western Australia	Ph (08) 9256 8600	Fax (08) 9455 1227

ARDEX New Zealand Ltd

Auckland	Ph (09) 5800 005	Fax (09) 5799 963
Wellington	Ph (04) 5685 949	Fax (04) 5686 376
Christchurch	Ph (03) 3843 029	Fax (03) 3849 779

Technical Services Toll Free: 1800 224 070

Date: July 2007



ARDEX WPM 5000HD

(Shelterseal 5000HD Membrane)

Cold application – installed without the use of open flames

Slip free surface – membrane provides an ideal, safe working surface

Ideal for parking decks and car parks, vehicular traffic structures and also expansion joints

ARDEX Australia Pty Ltd
20 Powers Road
Seven Hills NSW 2147
Tel: (02) 9851 9199
Fax: (02) 9674 5621
Email: techinfo@ardexaustralia.com
Internet: www.ardex.com

ARDEX New Zealand Ltd
32 Lane St, Woolston
Christchurch, New Zealand
Tel: (03) 384 3029
Fax: (03) 384 9779
Email: techinfo@ardexaustralia.com
Internet: www.ardex.com

ARDEX WPM 5000HD

(Shelterseal 5000HD Membrane)

1.5mm SBS Reinforced Self Adhesive Sheet Membrane

PRODUCT DESCRIPTION

ARDEX WPM 5000HD (Shelterseal 5000 HD Self Adhesive Membrane) is an industrial strength “peel and stick” bituminous/asphalt membrane. ARDEX WPM 5000HD is reinforced with a layer of polypropylene mesh giving the product exceptionally high mechanical characteristics.

ARDEX WPM 5000HD is made from two structural components:

- Bitumen/asphalt compound modified with SBS and high tack resins.
- A protective polypropylene mesh hot laminated to the bituminous/asphalt compound. This gives the membrane its mechanical and physical characteristics, such as heat and shape stability, chemical and puncture resistance.

FEATURES/BENEFITS

Cold Application

Installed without the use of open flames. Ideal for installation in restricted spaces.

High durability

Polypropylene mesh reinforcement layer provides tough, puncture resistant finish.

Constant thickness

The membrane is manufactured using the highest quality materials, standards and sheet manufacturing techniques.

Slip free surface

Membrane provides an ideal, safe working surface.

ACCEPTABLE SUBSTRATES

- Concrete, renders and screeds
- Fibre cement sheets
- Structural or marine plywood

For use over other substrates including existing membranes contact ARDEX.

TYPICAL APPLICATIONS

- Parking decks & car parks
- Vehicular traffic structures
- Expansion joints
- Underneath clay tiles or asphalt shingles
- Any applications where the waterproofing must have high mechanical characteristics

BASIC APPLICATION INSTRUCTIONS

Surface Preparation

Surfaces to which the ARDEX WPM 5000HD is to be installed must be properly prepared prior to installation. All surfaces must be clean, dry, smooth, free of sharp edges, loose or foreign materials, oil, grease, and other materials that may damage the membrane. If concrete has moisture on surface use gas torch to dry and warm before priming, or apply 1 coat of ARDEX WPM 300 at a coverage rate of 3.0m² per L and allow to cure for at least 3 days prior to proceeding.

Priming

Prior to the application of the membrane all prepared surfaces should be primed with ARDEX WPM 249 (Shelterseal Primer) at a rate of 5-6m² per litre and allowed to dry.

Application of ARDEX WPM 5000HD

ARDEX WPM 5000HD should always be applied from the lowest point to enable laps to shed water. All edge and end laps must be overlapped a minimum of 60mm. Internal and external corners shall be reinforced with an extra layer of membrane 300mm wide. All end laps and exposed edges shall be sealed with a bead of Self Adhesive Mastic.

On vertical surfaces the installation should start at the lowest point with the joints overlapping by at least 100mm, and formed so that they will shed water. All rolls of ARDEX WPM 5000HD are marked with a 60mm line for overlapping.

Ensure that the membrane is properly adhered to the surface at perimeters or around penetrations.

On completion of the installation of ARDEX WPM 5000HD it is necessary that protection board be used before back filling to protect the membrane from damage.

Under no circumstances should the membrane be left exposed to UV light for long periods.

Applying asphalt directly over ARDEX WPM 5000HD.

The asphalt should be applied as soon as possible after the Shelterseal membrane has been installed. ARDEX recommend applying a minimum 50mm compacted overlay for carpark areas. The topping should be applied at a temperature of between 120-150°C.

ARDEX WPM 5000HD should be installed by approved applicators, well trained in the application of self-adhesive membranes. Installation shall be strictly in accordance with ARDEX recommendations.

SAFETY PRECAUTIONS

ARDEX WPM 5000HD is hazardous; non-dangerous goods. Wear eye/face protection. Use only in well ventilated areas. Keep rolls in a well ventilated place. In case of contact with eyes, rinse with plenty of water and contact a doctor or Poisons Information Centre.

ARDEX WPM 249 is hazardous; non-dangerous goods. It is highly flammable, harmful if swallowed and irritating to the eyes and skin. Keep away from sources of ignition. No smoking. Keep container tightly closed and in a well ventilated place.

ADDITIONAL INFORMATION FOR ARDEX WPM 249 IS FOUND IN THE MATERIAL SAFETY DATA SHEET.

STORAGE

All rolls of ARDEX WPM 5000HD, whether palletised or loose, should be stored in a cool covered area protected against sunlight and UV radiation. Rolls should be stored in a vertical position on a smooth floor so as not to damage the edges.

ADDITIONAL INFORMATION IS LISTED IN THE MATERIAL SAFETY DATA SHEET.

PACKAGING

Roll size: 1m x 20m

Roll weight: Approx 30kg.

Other products: ARDEX Shelterseal Primer 5 litres and 20 litres.

Rolls per pallet: 25

TECHNICAL PERFORMANCE DATA

Properties	Typical Values	Test Method
Thickness	1.5mm	UNI 8202
Weight	1.6kg	UNI 8202
Colour	Black	
Softening point	110°C	
Temperature resistance (max.)	150°C	
Tensile strength		
Longitudinal	152kg/8cm	
Transverse	124kg/8cm	
Elongation (longitudinal)	32%	ASTM D638
Elongation (transverse)	21%	ASTM D638
Tearing		
Longitudinal	350N	UNI 8202/9
Transverse)	300N	UNI 8202/9
Adhesion		
To primed concrete	4.9 N/mm	ASTM D1000
To steel	5.8 N/mm	ASTM D1000
Puncture resistance	220 N/65mm	ASTM E96
Vapour transmission rate	0.3g/m/24hrs	ASTM E96
Cold flexibility	-30°C	ASTM D146

DISCLAIMER

The technical details, recommendations and other information contained in this data sheet are given in good faith and represent the best of our knowledge and experience at the time of printing. It is your responsibility to ensure that our products are used and handled correctly and in accordance with any applicable Australian Standard, our instructions and recommendations and only for the uses they are intended. We also reserve the right to update information without prior notice to you to reflect our ongoing research and development program.

Country specific recommendations, depending on local standards, codes of practice, building regulations or industry guidelines, may effect specific installation recommendations.

The supply of our products and services is also subject to certain terms, warranties and exclusions, which may have already been disclosed to you in prior dealings or are otherwise available to you on request. You should make yourself familiar with them.

ARDEX Australia Pty Ltd

New South Wales	Ph (02) 9851 9100	Fax (02) 9838 7970
Queensland	Ph (07) 3817 6000	Fax (07) 3881 3188
Victoria/Tasmania	Ph (03) 9308 9255	Fax (03) 9308 9332
South Australia	Ph (08) 8268 2511	Fax (08) 8345 3207
Western Australia	Ph (08) 9256 8600	Fax (08) 9455 1227

ARDEX New Zealand Ltd

Auckland	Ph (09) 5800 005	Fax (09) 5799 963
Wellington	Ph (04) 5685 949	Fax (04) 5686 376
Christchurch	Ph (03) 3843 029	Fax (03) 3849 779

Technical Services Toll Free: 1800 224 070

Date: July 2007



ARDEX Shelterseal

Associated Products

ARDEX Australia Pty Ltd
20 Powers Road
Seven Hills NSW 2147
Tel: (02) 9851 9199
Fax: (02) 9674 5621
Email: techinfo@ardexaustralia.com
Internet: www.ardex.com

ARDEX New Zealand Ltd
32 Lane St, Woolston
Christchurch, New Zealand
Tel: (03) 384 3029
Fax: (03) 384 9779
Email: techinfo@ardexaustralia.com
Internet: www.ardex.com

ARDEX Shelterseal

Associated Products

ARDEX WPM 249 PRIMER (SHELTERSEAL PRIMER) PRIMER FOR SBS SELF-ADHESIVE MEMBRANES

A solvent based bitumen modified primer designed to seal and prepare the substrate prior to the installation of ARDEX SBS (Shelterseal) Self Adhesive Membranes.

PRODUCT DESCRIPTION

Black liquid with strong solvent odour.

APPLICATION

Surface Preparation: Ensure that the surface to be primed is dry and free from dust, oil, paint, curing membranes, form release agents and all other contaminants.

Stir contents well before use.

Apply by brush or roller working the primer into the surface.

Primer must be dry before applying membrane.

COVERAGE

One (1) litre of ARDEX WPM 249 (Shelterseal) Primer will cover approximately 5m².

DRYING TIME

Approximately 20-30 minutes @ 23°C.

CLEAN-UP

Wash equipment with ARDEX WPM 290 (WA) solvent.

PACKAGING

20 Litres

SHELF LIFE

12 Months in original unopened packaging stored at 23°C.

LIMITATIONS

Primer should be used with appropriate mask and breathing apparatus in areas of poor ventilation and/or air flow.

SAFETY PRECAUTIONS

ARDEX WPM 249 is hazardous and a dangerous goods. It is highly flammable and irritating to the eyes and skin. No smoking. Harmful if swallowed. Keep away from sources of ignition. Keep container in a well ventilated place.

FIRE

ARDEX WPM 249 is highly flammable. Severe fire hazard when exposed to heat and/or oxidisers. Vapour may travel a considerable distance to source of ignition. Heating may cause expansion or decomposition leading to violent rupture of containers.

It is essential to ensure ARDEX WPM 249 Primer has fully dried before the Ardex Torch Applied Bitumen membranes are installed.

ADDITIONAL INFORMATION IS LISTED IN THE MATERIAL SAFETY DATA SHEET.

ARDEX PRESSURE SEAL

Membrane Protection

Designed to seal the edges of ARDEX Butynol or ARDEX Torch Applied Bitumen (Shelterbit) Membranes and ARDEX SBS Self Adhesive (Shelterseal) Membranes where no existing cavity flashing or dampcourse has been installed.

PRODUCT DESCRIPTION

3 metre lengths of specially formed aluminium strip.

INSTALLATION

The ARDEX Pressure Seal is mechanically fixed through the top edge of the membrane at 500mm intervals. The uppermost edge of the strip is then sealed with ARDEX Butynol Sealant along the profile provided.

PACKAGING

Packs containing 10 x 3 metre lengths.

ARDEX PROTECTION BOARD

Membrane Termination Seal

ARDEX Protection Board is a fluted polyethylene board designed to be used after the membrane installation and prior to backfilling to protect the membrane from mechanical damage during the backfilling operation.

SIZE

1,800 X 1,200mm fluted boards.

PACKAGING

Packs of 25 boards.



ARDEX Torch

Applied Membranes

Associated Products

ARDEX Australia Pty Ltd
20 Powers Road
Seven Hills NSW 2147
Tel: (02) 9851 9199
Fax: (02) 9674 5621
Email: techinfo@ardexaustralia.com
Internet: www.ardex.com

ARDEX New Zealand Ltd
32 Lane St, Woolston
Christchurch, New Zealand
Tel: (03) 384 3029
Fax: (03) 384 9779
Email: techinfo@ardexaustralia.com
Internet: www.ardex.com

ARDEX Torch Applied Membranes

Associated Products

ARDEX WPM 240 (SHELTERBIT PRIMER) PRIMER FOR BITUMINIOUS MEMBRANES

A solvent based bitumen modified primer to be used to seal and prepare the substrate prior to the installation of ARDEX Torch Applied Bitumen membranes.

PRODUCT DESCRIPTION

Black liquid comprising a bitumen cut dissolved in mineral spirits.

PACKAGING

5 litres and 20 litres.

SHELF LIFE

12 months in the original unopened packaging stored at 23°C.

COVERAGE

Coverage of ARDEX WPM 240 (Shelterbit) Primer is approximately 5m² per litre. Coverage will vary depending on the porosity of the substrate surface.

DRYING TIME

Approx. 1-2 hours @ 23°C.

APPLICATION

Surface preparation:

Ensure that the surface to be primed is dry and free from dust, oil, paint, curing compounds and any other contaminating materials.

Application:

Stir contents well before use. Apply by brush, roller or airless spray. Primer must be dry before applying membrane.

CLEAN UP

Wash equipment with ARDEX WPM 290 (Shelter WA) Solvent.

FLAMMABILITY

ARDEX WPM 240 Primer is classified flammable. It is essential to ensure the primer has fully dried before the ARDEX Torch Applied Bitumen Membranes are installed.

FIRST AID

Swallowed: Give water to clean mouth. Do not induce vomiting.
Skin: remove contaminated clothing. Wash skin thoroughly with soap and water.

Eyes: hold open and flood with water for at least 15 minutes.

Inhalation: remove to fresh air. If breathing is difficult administer oxygen.

If irritation continues seek medical attention promptly.

LIMITATIONS

Primer should be used with appropriate mask and breathing apparatus in areas with poor ventilation/air flow.

ARDEX PAVER SUPPORT PAD

ARDEX Paver Support Pads are pads specifically designed to protect ARDEX Sheet Membranes when laying pavers over the membrane.

The installation of Paver Support Pads also provides excellent drainage under the pavers thus avoiding the risk of paver flooding.

ARDEX Paver Support Pads are positioned at each corner of each paver installed as indicated in the diagrams below:-

PACKAGING

Pack of 300

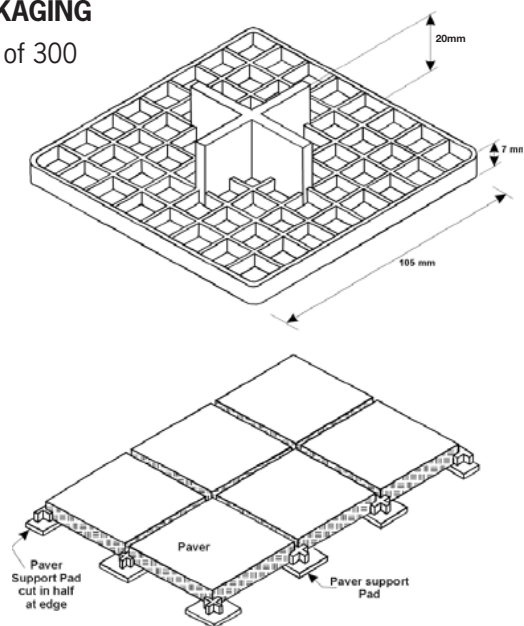

ARDEX DROPPER

Formed from Butyral rubber these Outlets are available in a range of sizes to suit various drainage piping. The Outlets are inserted into the pipe, sealed into the pipe with silicone and the ARDEX Sheet Membranes are torched or bonded directly onto the Outlet providing an easy, quick and secure watertight seal.

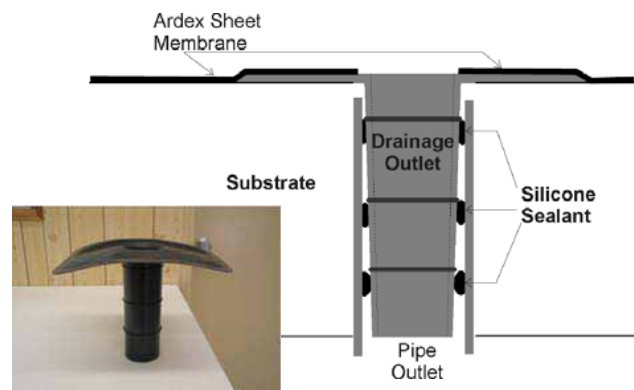

Stock Sizes

65mm OD

100mm OD

ARDEX SPITTER OUTLET

Formed from Butyral rubber these Outlets are used to seal the full extent of the outlet which would be otherwise impossible. Easy to install through parapet or balcony walls, etc. The ARDEX Sheet Membrane is bonded or torched to the flaps providing an easy, quick and secure watertight seal.

Outlet Dimensions

100 x 65mm

Outlet Length

420mm

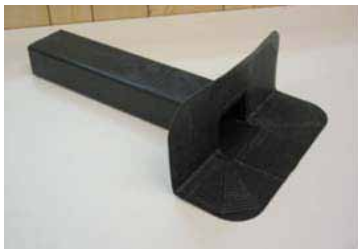
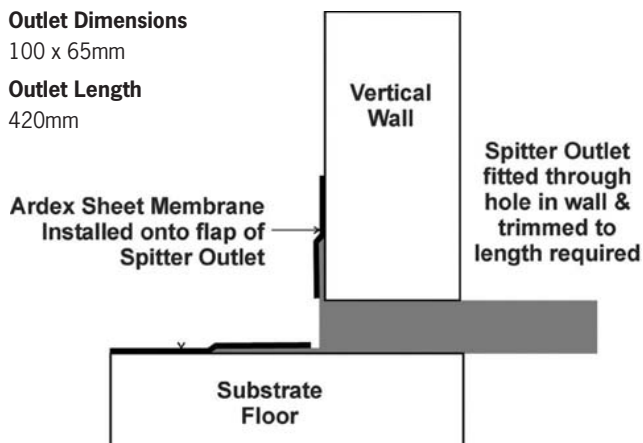

ARDEX SPITTER DOWNPIPE CONNECTOR

After the ARDEX Spitter Outlet has been trimmed to the correct length the Downpipe Connector links the Spitter Outlet to the drainage pipe for a neat easy connection.



ARDEX PRESSURE SEAL

Membrane Protection

Designed to seal the edges of ARDEX Butynol or ARDEX Torch Applied Bitumen Membranes and ARDEX SBS Self Adhesive Membranes where no existing cavity flashing or dampcourse has been installed.

PRODUCT DESCRIPTION

3 metre lengths of specially formed aluminium strip.

INSTALLATION

The ARDEX Pressure Seal is mechanically fixed through the top edge of the membrane at 500mm intervals. The uppermost edge of the strip is then sealed with ARDEX Butynol Sealant along the profile provided.

PACKAGING

Packs containing 10 x 3 metre lengths.

ARDEX PROTECTION BOARD

ARDEX Protection Board is a fluted polyethylene board designed to be used after the membrane installation and prior to backfilling to protect the membrane from mechanical damage during the backfilling operation.

SIZE

1,800 X 1,200mm fluted boards.

PACKAGING

Packs of 25 boards.

ARDEX VAPOUR VENTS

Substrate ventilation should be used to release moisture trapped under ARDEX Butynol or ARDEX Bitumen Sheet membranes. Substrate ventilators are used for this purpose. One way substrate ventilators prevent moisture vapour build up and one should be installed every 90 square metres. Not designed to ventilate roof cavities.

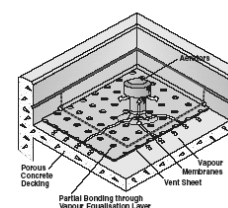
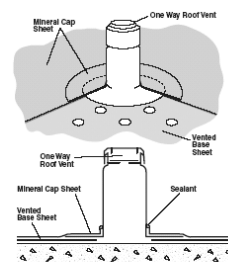

ARDEX Australia Pty Ltd

New South Wales	Ph (02) 9851 9100	Fax (02) 9838 7970
Queensland	Ph (07) 3817 6000	Fax (07) 3881 3188
Victoria/Tasmania	Ph (03) 9308 9255	Fax (03) 9308 9332
South Australia	Ph (08) 8268 2511	Fax (08) 8345 3207
Western Australia	Ph (08) 9256 8600	Fax (08) 9455 1227

ARDEX New Zealand Ltd

Auckland	Ph (09) 5800 005	Fax (09) 5799 963
Wellington	Ph (04) 5685 949	Fax (04) 5686 376
Christchurch	Ph (03) 3843 029	Fax (03) 3849 779

Technical Services Toll Free: 1800 224 070

Date: July 2007



Butynol®

Roofing

ARDEX Australia Pty Ltd
20 Powers Road
Seven Hills NSW 2147
Tel: (02) 9851 9199
Fax: (02) 9674 5621
Email: techinfo@ardexaustralia.com
Internet: www.ardex.com

ARDEX New Zealand Ltd
32 Lane St, Woolston
Christchurch, New Zealand
Tel: (03) 384 3029
Fax: (03) 384 9779
Email: techinfo@ardexaustralia.com
Internet: www.ardex.com

SPECIFICATION

A synthetic rubber with properties which resist ageing from heat, sunlight and ozone. It has excellent gas impermeability and toughness and remains flexible at low temperatures.

Butynol is manufactured by combining the petroleum gases isobutylene and isoprene at the extremely low temperature of -100°C . (*Rubber Technology-Morton*) Butynol is marketed by ARDEX as a warranted roofing and tanking product and fixed by their trained and experienced Approved Applicators.

BUTYNOL MATERIAL SPECIFICATIONS

Our requirements for long term warranty necessitate that Butynol meets these typical technical requirements:

Specific Gravity to ASTM D297	1.20±0.05
Hardness IRHD to ASTM D1415	65±5
Tensile Strength to ASTM D412	8.3 MPa min
Modulus at 300% elongation to ASTM D412	4.15 MPa min
Elongation at break to ASTM D412	300% min
Heat Ageing (7 days at 115° C)	
Tensile Retention to ASTM D412	70% min
Elongation Retention to ASTM D412	70% min
Tear Strength to ASTM D624	26kN/m
Ozone Resistance to ASTM D1149 (7 days at 40°C in 50pphm ozone)	No visible cracks
Water Permeability to ASTM E96-92 (mg/m ² .h at 35mm Hg)	2.9 at 32°C
(mg/m ² .h at 55.32mm Hg)	15.3 at 40°C

Sample ID	Vapour Flow Resistance (MNs/g)	Mean	Vapour Flow Rate	Mean
D2789 A	7840		0.014	
D2789 B	5880	12414	0.019	0.013
D2789 C	23521		0.005	

Note: Interesting comparable figures for water permeability are – Polythene 156, Asphalt 1830, P.V.C. 4900.

K Values on 1mm Butynol sheeting

K Value (Thermal Conductivity) 7.4×10^3
Cal/cm/sec/deg C.

Conductivity Data on 1mm Butynol sheeting

Resistance/m² Ω /m² = 0.6816 on 9.3 volts.

Seam Tape performance

Tests on the seam tape bonding method, by an independent testing laboratory, have shown average values equivalent to 90% of unwelded material.

It is considered impossible for the test methods used to be duplicated in normal service ie. 400% elongation.

BUTYNOL PROTECTS

Against water, moisture vapour, gases, sun, ozone, frost, acids, chemicals and bacteria.

BUTYNOL RESISTS

Tearing, flex cracking, bubbling and abrasion. It is extremely strong, has a long life and is versatile.

BUTYNOL IS PACKAGED

In rolls of nominal 1.4m width and 17.86m long. Each roll is packed in polythene wrapper trademarked BUTYNOL with thickness identified. Coverage 25m² except 2.25mm gauge which is 12m².

Gauges available are:

1.0mm black.	Weight: nominal 30kg
1.5mm black.	Weight: nominal 45kg
2.25mm black.	Weight: nominal 32kg
1.2mm dove grey.	Weight: nominal 30kg
1.5mm all colours.	Weight: nominal 47kg

ADHESIVES AND SOLVENTS

Specially formulated for all Butynol applications. Supplied in 20L steel pails (approx. 20kg). 4 and 1 litre cans.

SEAM TAPE

Uncured Butyl Cold Gum tape supplied by ARDEX. Supplied in 50mm x 30.5m rolls (6 to a carton). Used for general lap bonding and laps likely to be subject to periodic ponding.

BUTYNOL SEALANT

Available in tubes for caulking guns.

DETAIL TAPE

A Malleable exterior tape for flashing exterior corners etc. 150mm x 30.5m rolls.

FLASHING TAPE

A malleable tape for moulding in gussets, pipe flashings and awkward situations. Supplied in widths of 50-100mm x 5m. Flashing tape must not be left exposed. A Cover strip of Butynol must be applied over flashing tape to finish.

BRANZ APPRAISED

BRANZ Appraisal Certificate No 436 (2003)
Butynol Roofing Membrane has been issued.
Copy available on request.



BUTYNOL GAUGES

- Standard 1.0mm** – For roofs and gutters.
- 1.2mm** – For roofs.
- 1.5mm** – For roofs and walk out decks.
- 2.25mm** – Heavy Duty

Factory welded panels in all gauges can be custom made.

SUBSTRATE VENTILATION

Substrate ventilation should be used to release moisture trapped under the Butynol. Substrate ventilators are used

in conjunction with vent tapes. Tapes should be laid in a grid pattern spaced at 600mm venting to the roof perimeter. One way substrate ventilators prevent moisture vapour build up and one should be installed every 90 square metres. Not designed to ventilate roof cavities. (Refer Diagram page 2/16)

PLYWOOD TREATMENT

In normal use plywood substrate does not require treatment when used under Butynol. NZS 3602:1995 Table 2B Amendment No. 1 August 1996.

DURABILITY

Butynol when fixed according to ARDEX instruction will meet the NZBC requirements of B2.3.1(b) 15 years. Case history of the product in use show applications in excess of 30 years without any additional protection.

EXTERNAL MOISTURE

New Zealand Building Code Acceptable Solution.

E2/AS1 requirements recommend membrane clad roofs have a minimum pitch of 1.5°.

DAMP AND WEATHERPROOFING

The Building Code of Australia Deemed-to-Satisfy Provisions F1.9 and F1.10 are met by Butynol as an acceptable dampproof course. Butynol when used as described in ABSAC Technical Opinion 188 August 1994 complies with the Building Code of Australia Deemed-to-Satisfy Provision F1.7(b) and Acceptable Construction Manual Part 3.8.1.0, or AS 3740 for "Water Proofing of Wet Areas in Buildings".

FIRE RATING

The Butynol roofing system must be considered combustible but may be used on buildings for all purpose groups, subject to the requirements of NZBC Acceptable Solution C/AS1 Part 7, Paragraph 7.11.1

When used for roofs in Purpose Groups SC and SD a non-combustible substrate or timber 18mm thick is acceptable. Refer 7.11.1.

Building Code of Australia allows use in all building types under Specification C1.10, Clause 7(e), except in bush fire prone areas.

PRODUCT WARRANTY

Butynol when laid by a ARDEX Approved Applicator is only covered for up to 20 years if a written material warranty has been requested and provided.

WORKMANSHIP

A warranty for workmanship shall be provided by the Approved ARDEX Applicator. The period of the workmanship warranty shall be determined by the Approved Applicator.

ADHESIVES AND SOLVENTS FOR USE WITH BUTYNOL

ARDEX WA 98 – The standard contact brushing, spray grade and rolling adhesive for fixing to the substrate and for laps not subject to periodic ponding.

ARDEX WPM 299 Seam Primer – A Water resistant primer adhesive, used with seam tape for general lap bonding.

Note: Temperature and Humidity

The evaporation of any solvent adhesive system causes a drop in temperature at the interface. At times of high humidity this can result in a micro molecular water layer at the interface which will result in a failure to bond, falsely attributed to adhesive failure. Fixing should not proceed under these circumstances.

NOTES

1. In cases of extreme absorbency, a priming coat of full strength ARDEX WA 98 Adhesive may assist water shedding and absorption. However, a follow up of full strength adhesive for full bonding should not be proceeded with under four hours, thus allowing full evaporation of solvents absorbed into the substrate. Primers must be time dried not touch dried.
2. As new substrate materials continually appear on the market, consult ARDEX for approval of their use with Butynol.
3. Where periodic ponding is likely and on roofs with a slope of 5° or less, ARDEX Seam Tape and ARDEX WPM 299 Seam Primer must be used on all joints.
4. Laps can be formed on roofs with a pitch greater than 5° with normal brush grade substrate ARDEX WA 98 Adhesive. Laps must be solvent wiped with ARDEX WA 985 solvent prior to applying adhesive. They must however at all times drain dry and have no periodic ponding.
5. Do not use in temperatures less than 6°C.

CAUTION

All Adhesives and Solvents are HIGHLY FLAMMABLE.

BUTYNOL SEALANT

Description

Butynol Sealant has been specially designed and formulated for sealing Butynol flashings into chases as found in Building and Construction. Butynol Sealant gives excellent adhesion and sealant to both Butynol Membranes and building substrates. Available in black or grey.

DANGER

Gives off highly flammable vapour. Keep well away from heat, sparks and open flame. Keep closed when not in use.

AVOID BREATHING VAPOUR

Use with adequate air flow.

DIRECTIONS

Once the Butynol Membrane has been fixed into place apply an even bead of Butynol Sealant into the chase, which should be properly prepared by ensuring all surfaces are clean, dry and sound. Tool the sealant bead to ensure there are no voids, gaps or air pockets and that the bead has a neat and flush finish. Cut the cartridge nozzle to give the desired aperture and angle. For best results the sealant should be gunned by pushing the cartridge nozzle forward during application.

TACK FREE TIME:

Approx. 24 hours, depending on temperature conditions, can be painted within 4 to 6 days.

FULL CURE TIME:

4-6 days depending on temperature conditions.

CLEAN UP:

Clean tools, etc., with mineral turps.

COLOUR:

Black in 375ml tubes.

Also available for Butynol

Seal 'n' Flex Polyurethane
600ml sausages Colours - black and grey
Silaflex MS 300ml tubes Colour - grey

BUTYNOL RUBBER ROOFING SPECIFICATION

1. PRELIMINARY

Refer to the Preliminary and General Clauses of this specification and to the General Conditions of Contract which are equally binding on all trades. This section of the specification shall be read in conjunction with all other sections.

2. SCOPE

This section of the contract consists in general of the provision and laying of all the Butynol rubber, for the roofs, decks, gutters and flashings on the buildings. Refer to Clause 12 hereafter for Extent of Work.

3. WORKMANSHIP

The whole of the work shall be carried out by skilled tradesmen using adequate and proper equipment and methods in accordance with best trade practice, and following the specifications methods and recommendations as laid down by the manufacturers.

4. SUB-CONTRACTORS

The work included in this section of the contract shall be carried out by a firm of roofing experts conversant with and specialising in the supply and fixing of this material and shall be a firm approved by ARDEX and the architects.

5. GUARANTEE

The Butynol roofing contractor shall furnish to the main contractor a written guarantee that the Butynol rubber roofing, guttering and flashing together with the adhesives employed will remain watertight and free from any defects that permit the entry of water for a period of twenty (20) years after the installation of the product. Such guarantee shall cover the making good of any defects that may occur from defective materials. The roofing contractor shall obtain from the manufacturer of Butynol rubber sheeting and the adhesives a guarantee covering their materials and shall deliver the guarantee to the Architect. The Butynol Installer shall during the course of this subcontract and at completion make a thorough inspection of the works in order to undertake to furnish a written statement to the main contractor to the effect that all the Butynol roofing, gutters and flashings have been inspected and passed as being fixed strictly in accordance with ARDEX recommendations and instructions and best trade practices.

6. MATERIALS

6.1 Butynol Rubber

(a) Shall be 1.0mm thick standard Black Butynol rubber to all roof surfaces, gutters and fascias and walk out decks where membrane is to be overlaid with tiles.
(b) Shall be 1.5mm thick Butynol to all walk out decks.

6.2 Adhesives

Shall be as recommended by ARDEX specially formulated for Butynol rubber and suitable for the particular application and the relevant temperature and conditions applicable. Generally the normal adhesive for substrate

and lap bonding shall be ARDEX WA 98 Adhesive. Primer for lap bonding shall be ARDEX WPM 299 Seam Primer used in conjunction with ARDEX seam tapes. When conditions are experienced that are outside the temperature and/or moisture ranges recommended by the manufacturers for the above standard adhesives work will cease.

6.3 Seam Tapes

Shall be as supplied by ARDEX and shall be uncured Butyl Cold Gum tape (Refer ARDEX seam tape). For general lap bonding the tape shall be 50mm in width.

6.4 PVC Tape

All Plywood joints shall be taped with an approved PVC pressure sensitive self adhesive tape of 25mm width or ARDEX approved alternative.

7. ROOF DECKINGS

Shall be 1.5mm thick Butynol for all deck surfaces. All decks to which Butynol is to be fixed shall be clean, smooth, dry and free from dirt, grit or sharp objects. All decks, concrete or sheet materials shall be primed with 50/50 ARDEX WA 98 and ARDEX WPM 290 solvent. The Butynol roofer shall co-operate with the other trades laying the decking to ensure that the final surface is in first class condition for the laying of the Butynol rubber roofing.

On concrete decks arrange to prime the decks after initial curing again to immediately cover by roofing or the provision of temporary waterproof covers. The Butynol roofer shall check the deck before laying any Butynol to ensure that the surface is completely sound, screw fixed to specifications: screw heads flush, sheets spaced to provide for hydro expansivity, and if plastered concrete that there is no drumminess.

8. LAYING OF BUTYNOL ROOFING

It is the responsibility of the Applicator to ensure that the surface to be covered by the Butynol is in fit and proper condition, suitable in all respects for the laying of the material. Tape all joins in substrate sheets with 25mm wide PVC pressure sensitive tape or ARDEX approved alternative. Apply adhesive to the substrate and the underside of the Butynol rubber sheeting by brush, spray or an approved type roller at a spreading rate of generally not less than 2.5 square metres per litre. Leave to tack dry observing the minimum and maximum allowable times set by the adhesive manufacturer, before bonding the two surfaces together. Lay sheeting by drawing back halfway either longitudinally or transversely. Thoroughly roll or work over the surface of the sheet to exclude all air and to obtain a full bond. In general - all Butynol sheeting shall be laid out on the roof to "relax" the sheeting before fixing. A period of at least 20 minutes is usually required. Do not finally position sheeting with a tension exceeding 2%. All sheeting to the roofs shall be laid out as indicated on the roof plan, ie, at across the slope to an even Patter. End laps shall be avoided wherever possible but where necessary to the Architects approval. All roofs and/or gutters shall be "lap bonded" at all joints. Lap bonding shall be with ARDEX Seam Tape and ARDEX Seam Primers.

Bonding Laps with ARDEX Seam Tape and ARDEX WPM 299 Seam Primer

Following laying of the Butynol the laps must be sealed. Roofs with a pitch of less than 5° and all guttering and areas subjected to periodic ponding require special lap bonding.

1. The top lap is positioned and the bottom sheet marked to indicate the edge of the top sheet.
2. The top sheet is folded back.
3. The ARDEX WPM 299 Seam Primer is then applied to the Butynol in the area marked on the bottom sheet and 50mm in from the edge on the top sheet. The ARDEX WPM 299 Seam Primer is applied to the mating surfaces using a synthetic scrubbing pad. Scrubbing pads should be replaced as they become dirty. Allow the primer to become 'dry to the touch'.
4. Position and unroll the 50mm ARDEX Seam Tape along the seam. The edge of the release paper should be aligned to the mark on the bottom membrane sheet.
5. Roll the length of the seam with the release paper still in place.
6. Remove the release paper from the ARDEX Seam Tape by pulling at a 45° angle away from the seam. Keep the release paper low to the roof surface as it is removed.
7. Fold into place the primed edge of the top sheet.
8. Roll the completed seam.

9. TILING OVER BUTYNOL

To direct fix tiles to Butynol, ABA Optima two part adhesive should be used. Ensure the Butynol surface is clean and dry before applying the adhesive. All laps must have seam tape.

10. PROTECTION OF LAID BUTYNOLSHEETING

The Butynol roofing contractor shall ensure that his fixers only work on the Butynol roofing with soft sole shoes. The Butynol roofer shall co-ordinate with the main contractor who shall ensure that any other trades who work over the completed roof wear soft sole shoes.

Upon completion of each area the roofer shall get the main contractor to inspect the area and the main contractor will sign off that the area was free from any defects or damage. It is then the responsibility of the main contractor to ensure the Butynol roofing is in no way damaged by other trades.

11. COMPLETION

On completion of this roofing carefully and thoroughly clean off and remove all scraps and other rubbish from finished surfaces and leave in tidy order with the whole roof waterproof and in first class condition.

12. EXTENT OF WORK

Observe the foregoing specification and supply and lay Butynol rubber sheeting to all roofs, decks, gutters and flashings as shown and detailed on the drawings.

Failure to comply with the above specifications will result in all warranties being null and void.

SUBSTRATE SPECIFICATION

All surfaces to which Butynol is to be fixed shall be clean, smooth, dry and free from sawdust, grit or sharp objects. Plywood must be sanded on one side and free from knots. CD Grade Construction Plywood as specified in NZS 3602:1995 Table 2B Amendment No. 1 August 1996, and in conjunction with Australian/New Zealand Standard 2269:1994. Sarking should be overlaid with Plywood, giving an ideal laying surface.

For normal conditions the Plywood substrate should be 17.5mm and fixed with 3mm gaps between all sheets, and counter sunk screw fixed to Plywood manufacturer's specifications. Fixing centres: edges 150mm, intermediates 200mm. Note that there may be a requirement for closer screwing of the Plywood substrate to suit the particular situation. Plywood is to be laid with the face grain at right angles to the supports. Where roofs are over damp conditions adhesive fixing should be used with screws. Plywood must have sufficient ventilation. Insufficient ventilation will require treatment in line with NZS 3602:1995 Table 2B Amendment No. 1 August 1996. Refer to Plywood manufacturers for screw specification. Staples and nails are not suitable in any circumstances. NOTE: The use of LOSP (Light Organic Solvent Preservative) treated Plywood or composite boards of any type or density must not be used under Butynol in any circumstances or conditions.

Joins in plywood sheets are to be taped using 25mm Polyethylene tape. Plywood substrates with right angled internal corners should have a triangular fillet 50mm x 50mm screwed to each corner. External corners should be rounded to reduce wear on edges and allow an improved finish. Downpipe outlet holes should be drilled through timber boxed gutters and decks before installation. Butynol must have a 150mm minimum upstand on decks, therefore provision must be made for timber backing. It is important to leave doors and windows out until Butynol has been fixed. A steel trowel finish is required on all concrete surfaces. New concrete must be cured a minimum of 28 days prior to Butynol installation.

If any patch or filling of substrate is required it is best to use a fibreglass material, or an ARDEX floor laying compound to resist the heat absorbed through the black Butynol, so it will not break up causing bubbling.

Pumice surfaces are not recommended as a suitable substrate for Butynol. Light weight concrete surfaces require saw cut grooves for venting purposes.

On large areas of Plywood, sheets may be preprimed before being screwed to roof framing, to speed the application of the Butynol. Temperature on the substrate surface must not drop below 6°C for adhesives to go off.

LAYING SPECIFICATION

The Sub contractor for the work called for in this trade will be a Company or Person Accredited by ARDEX. The Accredited Applicator (hereafter called the Applicator) shall examine all drawings and provide for the flashing, caulking and sealing of all vents, stacks and pipes penetrating the roofing membrane. Also all flashings at walls, parapets, verges, gutters etc., unless otherwise instructed in the specifications.

The surface to which Butynol is to be fixed shall be clean, smooth, dry and free from sawdust, grit or sharp objects. Membrane laying shall not start until defects have been corrected.

It is the responsibility of the Applicator to ensure that the surface to be covered by the Butynol is in fit and proper condition, suitable in all respects for the laying of the material.

On completion the Applicator will provide the owner with a Workmanship Warranty and obtain from ARDEX a Materials Warranty.

Failure to comply with the above specifications will result in all warranties being null and void.

LAYING THE BUTYNOL

Before applying the Butynol, it shall be unrolled for twenty minutes to relieve stresses induced by manufacture and storage. The Butynol sheet shall be set out in the exact position in which it will be finally required and while it is held in place, it shall be folded back lengthwise to expose half the underside. To the now exposed underside and the area of roof also left exposed, apply an even coat of ARDEX WA 98 Adhesive. When the adhesive has become touch dry, work the sheet back into its original position avoiding wrinkles and the inclusion of air bubbles. Repeat the process with the other half of the sheet and when completed, roll the whole sheet with hand press rollers or the like. When applying the next sheet, it shall be lapped over the first sheet by 50mm. All turn ups and downs shall be neatly formed and cut to a straight line if necessary. Butynol shall not be laid under tension. When the whole area has been covered or as work progresses, the applicator has to seal the laps.

BUTYNOL LAYING METHOD

STEP 1

Accurately place sheet. Mark spacing with chalk line.

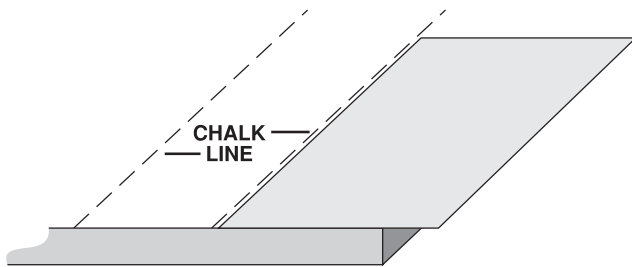

STEP 2

Fold back half sheet. Apply adhesive to both faces.

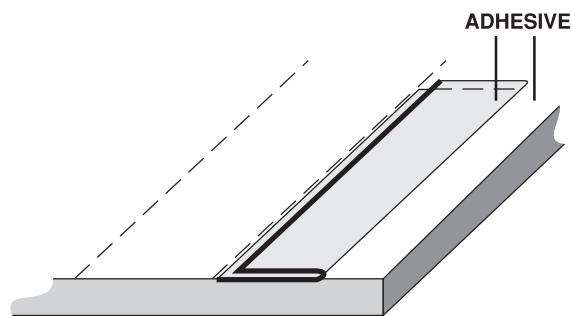

STEP 3

After flash off, fold membrane into place. Roll thoroughly.

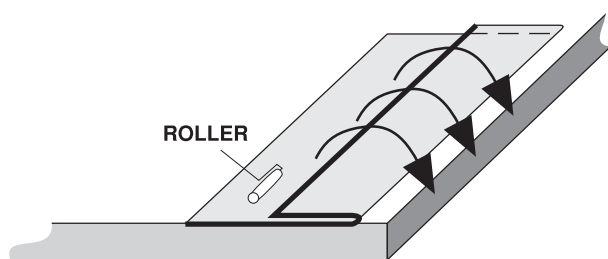

STEP 4

Treat 2nd half of Butynol similarly.

BONDING THE LAPS

Roofs with a pitch of less than 5°, all coloured membranes and all guttering and areas subjected to periodic ponding require special lap bonding.

All coloured membranes, irrespective of pitch require special lap bonding.

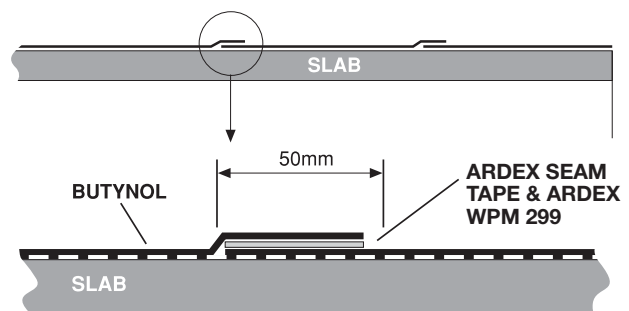

1. The top lap is positioned and the bottom sheet marked to indicate the edge of the top sheet.
2. The top sheet is folded back.
3. The ARDEX WPM 299 Seam Primer is then applied to the Butynol in Butynol Guttering the area marked on the bottom sheet and 50mm in from the edge on the top sheet. The ARDEX WPM 299 Seam Primer is applied to the mating surfaces using a synthetic scrubbing pad. Scrubbing pads should be replaced as they become dirty. Allow the primer to become 'touch dry'.
4. Position and unroll the 50mm ARDEX Seam Tape along the seam. The edge of the seam tape should be aligned to the mark on the bottom membrane sheet. The see-through film makes this very simple.
5. Roll the length of the seam with backing film still in place.
6. Remove the backing film from the ARDEX Seam Tape by pulling at a 45° angle away from the seam. Keep the release paper low to the roof surface as it is removed.
7. Fold into place the primed edge of the top sheet.
8. Roll the completed seam.

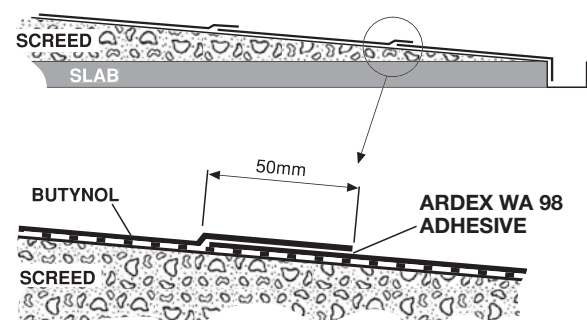

Butynol®

Roofing

Black Butynol and roofs with minimum pitch of 5° and sufficient fall to prevent periodic ponding may be formed using the sheet bonding adhesive ARDEX WA 98. All laps must be wiped with ARDEX WA 290 solvent prior to bonding.

FORMING LAPS FOR GUTTERS

Laps are most important in gutter work and should be and formed using ARDEX seam tape and ARDEX WPM 299.

All internal boxed gutters can be easily formed to any shape or size using Butynol over any specified substrate.

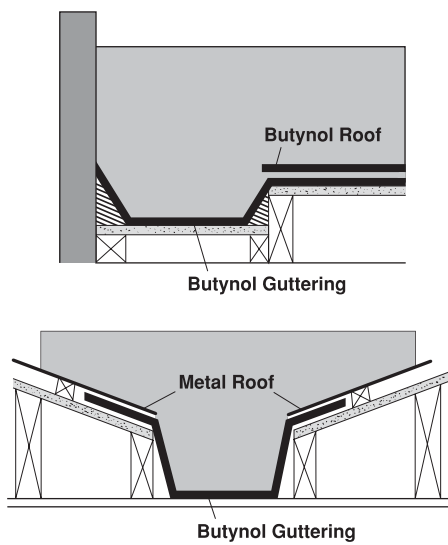

CROSS SECTION OF RAINHEAD

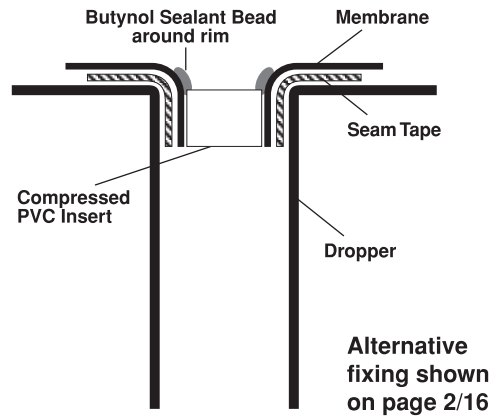

RECOMMENDED BATTEN PROFILE

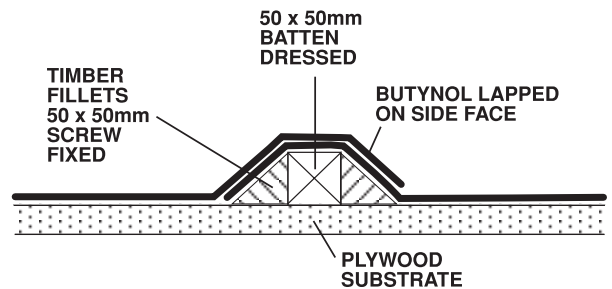

Battens arranged to suit plywood sheet sizes or visual effects

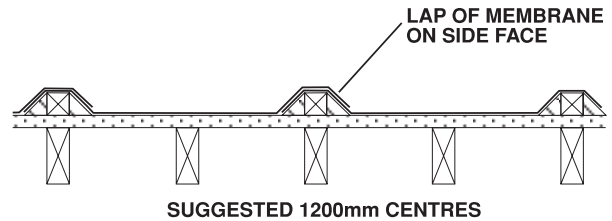

Example of a 1400mm sheet of Ardex Butynol dressed over battens at 1200mm centres

CROSS SECTION OF DROPPER

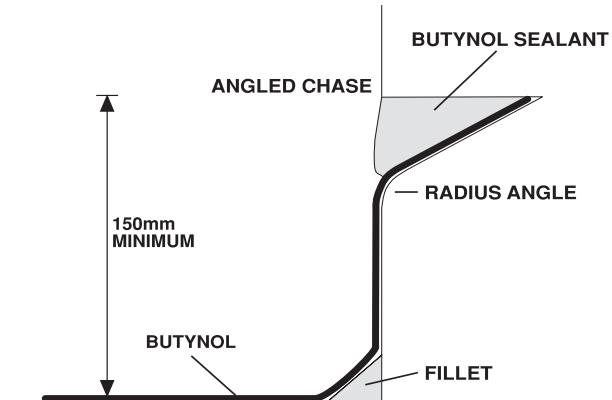
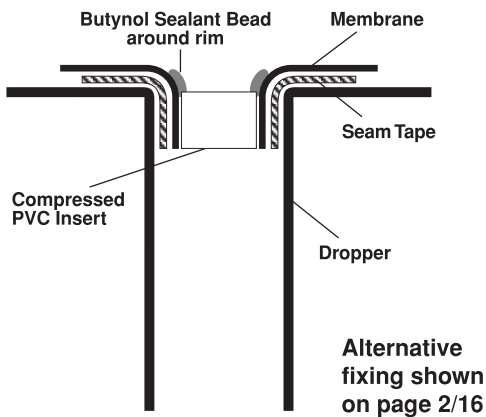

BUTYNOL is glued into angled chase and finished with Butynol Sealant.

FLASHING INTO CONCRETE WALLS EXTERNAL CORNERS

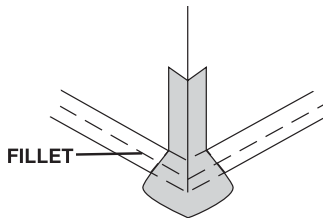

Step 1

Bond 100mm flashing or detail tape to corner as shown.

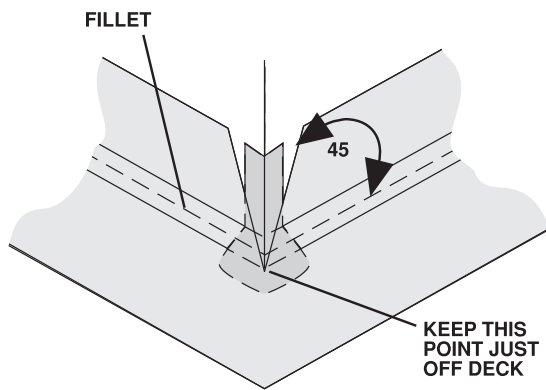

Step 2

Bond BUTYNOL to deck and up wall 150mm minimum. Cut sheet from corner at 45° as shown.

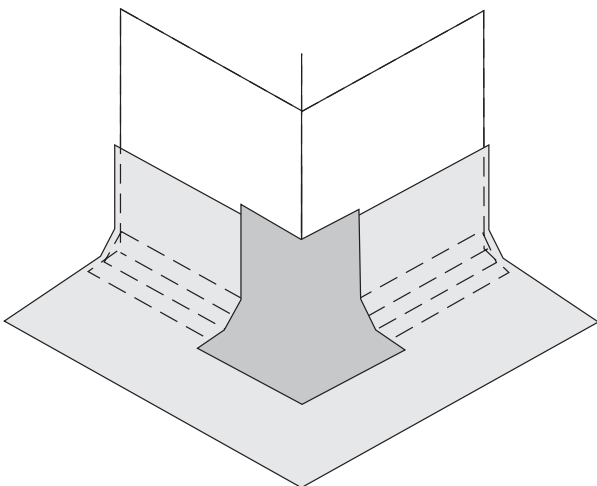

Step 3

Cover corner point with layer of detail tape.

NOTE: Fillets must be used on all internal corners.

INTERNAL CORNERS

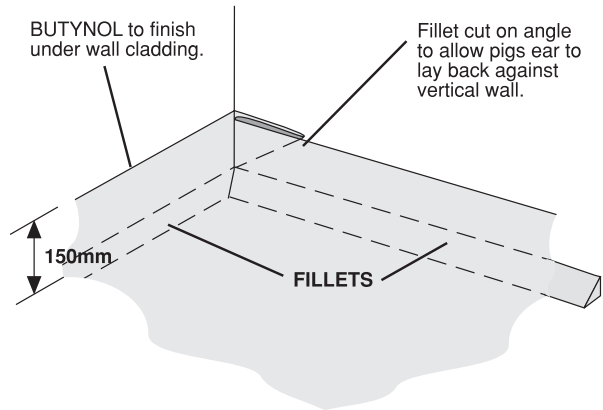

Step 1

Without cutting BUTYNOL simply fold a 'pig's ear' corner as shown. the angle fold should be behind the main sheet.

NOTE: Fillets must be used on all internal corners.

FLASHING - EXISTING PIPES

Step 1

Under flash pipe with 100mm BUTYNOL flashing tape.

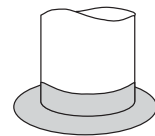

Step 2

Bond BUTYNOL to 100mm past pipe.

N.B. When flashing black BUTYNOL use black detail tape.

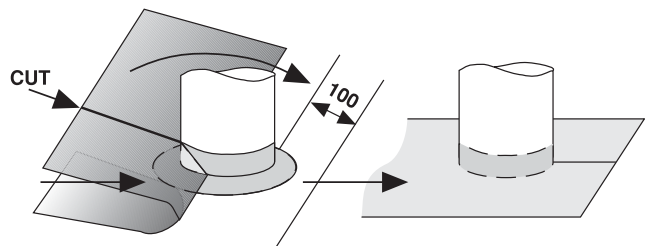

Step 3

Bond continuation of BUTYNOL to overlap base sheet and beyond pipe 100mm.

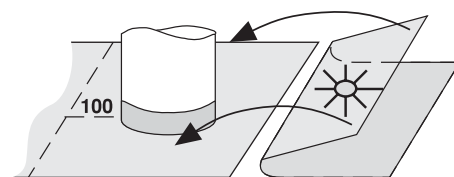

Step 4

Apply another collar of flashing tape, then bond final 70mm cover strip. **DO NOT STRETCH STRIP.**

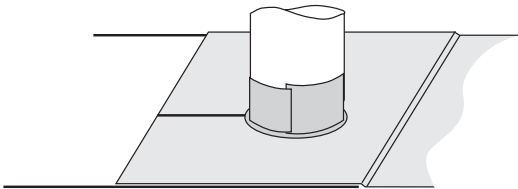

N.B. Flashing tape MUST NOT be left exposed. Cover strip must be BUTYNOL. When detail tape is used a cover strip of BUTYNOL is not required.

FLASHING - NEW PIPE

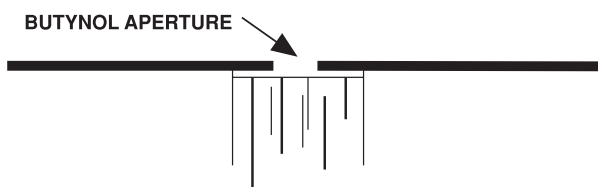

Step 1

Pipe is raised through smaller diameter hole in BUTYNOL, forcing edge upwards to create upstand

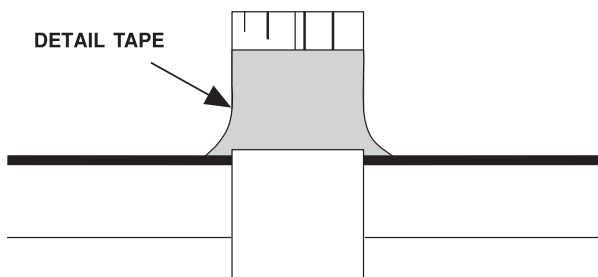
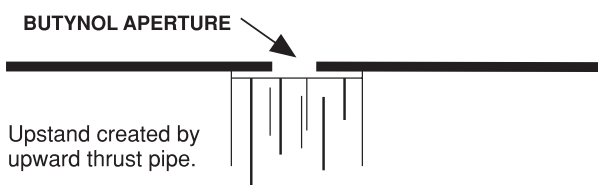

Step 2

After pulling pipe down approximately 1 cm to sharpen corner, tape upstanding BUTYNOL to pipe using ARDEX WA 98 Adhesive and detail tape. Upstand may be mechanically secured using a steel band.

N.B. If flashing tape is used it MUST NOT be left exposed. A cover strip of BUTYNOL must be applied over the flashing tape to finish.

TAPING SUBSTRATE SHEET

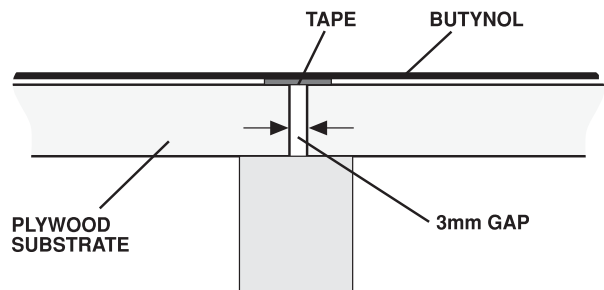

All joints between substrate sheets of Plywood should be taped to prevent stressing of the BUTYNOL in case of marked timber movement.

BOXED GUTTER AND PARAPET DOWNTURN

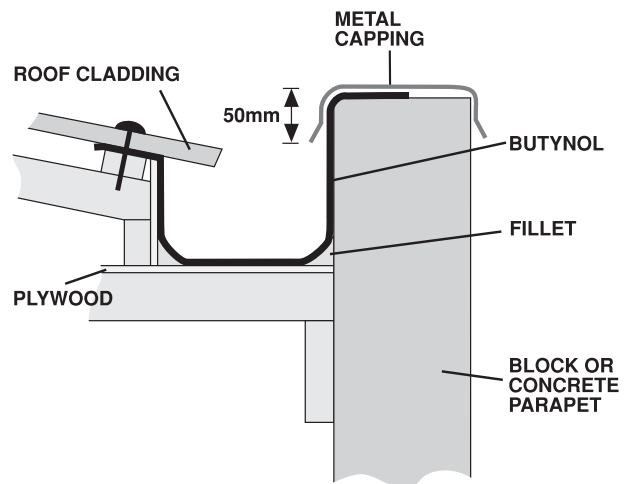

FORMING DOWNTURN IN GUTTER FOR CIRCULAR DOWNPIPE

Cut P.V.C. pipe should be compressed into smaller diameter, then coated with ARDEX WA 98 Butynol Adhesive and inserted in Downpipe finishing just below flush. Finished with a bead of Butynol Sealant.

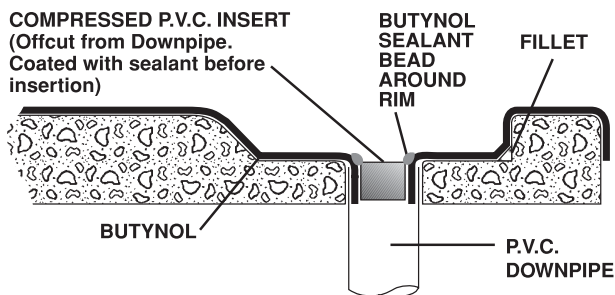
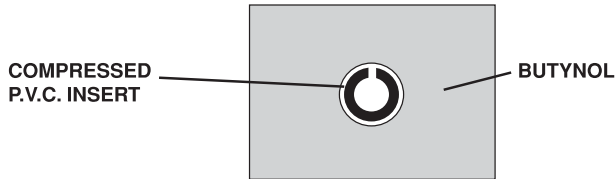

FINISHING OVER A GUTTER

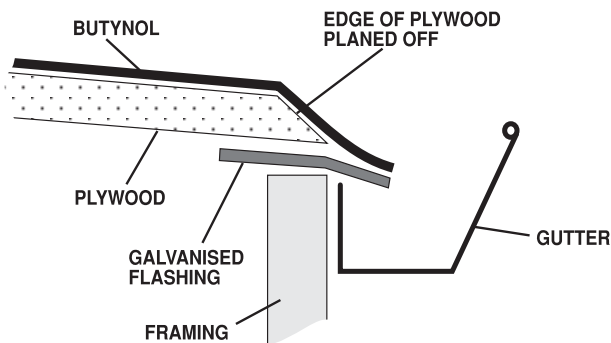

INTERNAL ROOF DRAIN

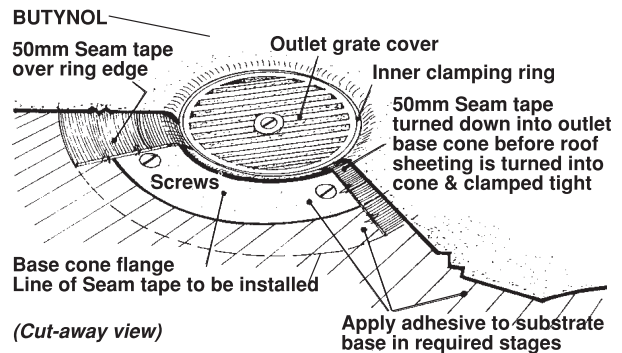
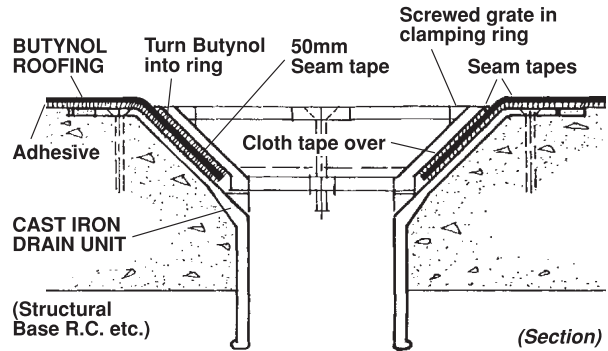

ONE WAY SUBSTRATE VENTILATOR PVC OR ALUMINIUM

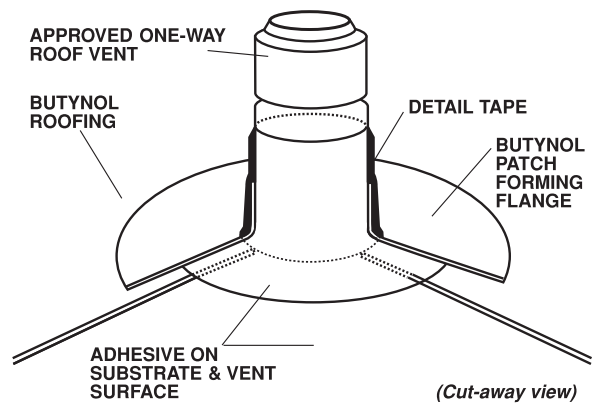

Vent installed over intersection of vent tapes on concrete substrate

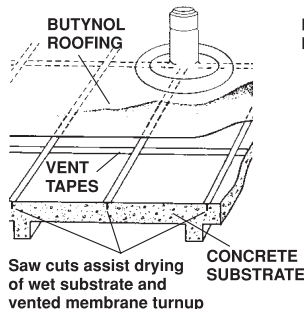

Vent installed over intersection of 3mm gap between Ply substrate sheets.

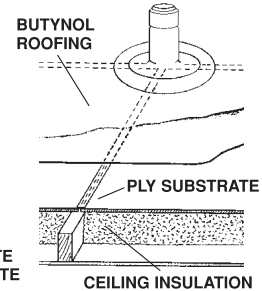

TYPICAL IRMA ROOF DETAIL

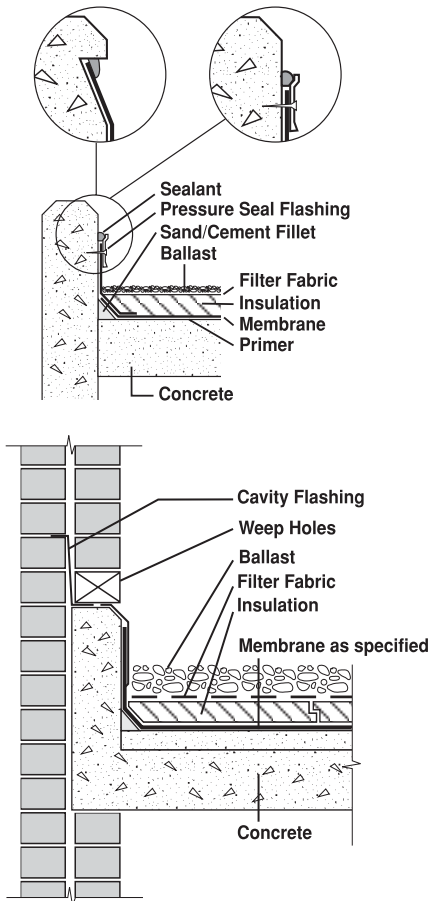

IRMA ROOF OVERFLOW

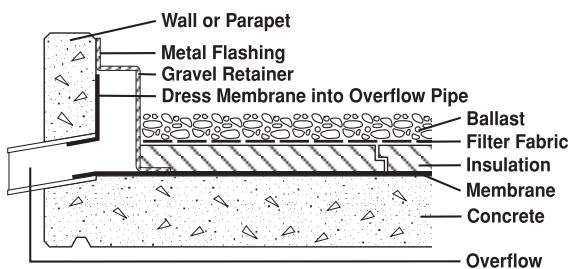

IRMA ROOF OUTLET & GRAVEL RETAINER

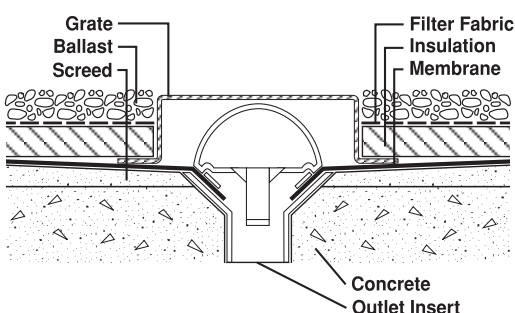

Loose Laid Application of Butynol Roofing

Materials used shall be as previously specified. When the surface is suitably prepared a large fully vulcanised Butynol sheet or sheets can be unrolled and spread over the prepared area and allowed to remain in this position for approximately one hour to relieve stresses induced by manufacture and storage. If necessary for ease of handling, these sheets can be supplied in varying sizes and vulcanised on site using an ARDEX vulcanising machine or using seam tape with ARDEX WPM 299 seam primer.

The Butynol sheet shall be set out in the exact position in which it will be finally required and whilst it is held firmly in place it shall be folded back at least one metre from the roof's surrounding parapet or wall to allow the application of adhesive to that area of the exposed substrate.

ARDEX WA 98 Adhesive may be applied to the substrate and the corresponding area of BUTYNOL sheeting which may then, when the adhesive is touch dry, be worked back into its required position avoiding wrinkles and the inclusion of air bubbles.

Upon completion of the detail work, parapets, drains and rainheads etc a layer of rounded gravel 30-40mm should be applied up to 50mm deep, over a layer of Geo Textile Fabric for protection of the Butynol sheet.

Care must be taken at outlets to ensure the ballast cannot enter or cause a blockage that prevents rainwater from leaving the roof area. Maintenance paths should be created to air-conditioning or roof plant with concrete tiles.

Effects on the membrane in areas of high wind can be eliminated by stabilising the ballast with cement. Dry cement should be broadcast over the 30-40mm gravel with a broad mouth shovel and left to hydrate or lightly sprayed with water to set off.

If possible a water test should be carried out prior to the application of ballast.

Note: Minimum pitch 1.5° to comply.

SCUPPER OUTLET

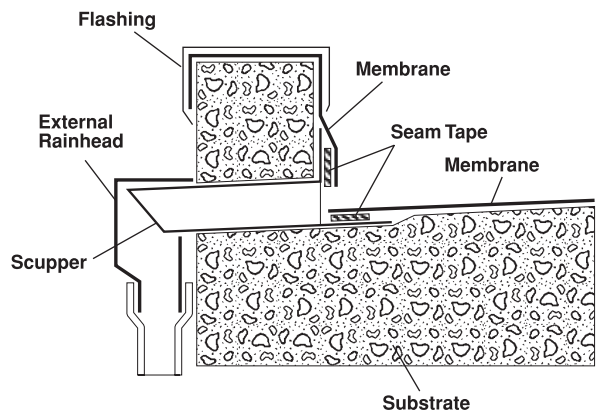



Butynol Installation

Associated Products

ARDEX WPM 290 Solvent

ARDEX WA 98 Adhesive

ARDEX Seam Tape

ARDEX Pressure Seal

ARDEX Seam Primer

ARDEX Butynol Sealant

ARDEX Australia Pty Ltd
20 Powers Road
Seven Hills NSW 2147
Tel: (02) 9851 9199
Fax: (02) 9674 5621
Email: techinfo@ardexaustralia.com
Internet: www.ardex.com

ARDEX New Zealand Ltd
32 Lane St, Woolston
Christchurch, New Zealand
Tel: (03) 384 3029
Fax: (03) 384 9779
Email: techinfo@ardexaustralia.com
Internet: www.ardex.com

Butynol Installation

Associated Products

ARDEX WPM 290 SOLVENT (SHELTER WA 98 SOLVENT) SOLVENT FOR ARDEX WA 98 ADHESIVES

A high aromatic hydrocarbon solvent designed for general purpose clean-up and preparation procedures prior to the installation of ARDEX Butynol Membranes.

PRODUCT DESCRIPTION

A synergistic blend of high aromatic hydrocarbon solvents.

PACKAGING

20 Litres

SHELF LIFE

2 years

COVERAGE

Not applicable

DRYING TIME

Approx. 20-30 minutes at @ 23°C.

APPLICATION

For preparation of Butynol membranes surfaces should be cleaned by scouring with ARDEX WPM 290 (Shelter WA 98) solvent.

CLEAN UP

Wash skin that has come in contact with ARDEX WPM 290 (Shelter WA 98) solvent with warm water and detergent. Application of skin moisturisers is recommended after use.

SAFETY PRECAUTIONS

ARDEX WPM 290 is hazardous and a dangerous goods. It is highly flammable and irritating to eyes and skin. No smoking. Harmful if swallowed. Keep away from sources of ignition. Keep container tightly closed and in a well ventilated place. In case of contact with eyes, rinse with plenty of water and contact a doctor or Poisons Information Centre.

ADDITIONAL INFORMATION IS LISTED IN THE MATERIAL SAFETY DATA SHEET.

ARDEX WA 98 ADHESIVE (ARDEX WA 98 ADHESIVE) BUTYNOL ADHESIVE

Specially formulated adhesive for all Butynol applications including broadspan bonding and lap jointing in non-aggressive or non-immersed condition exposure.

Supplied in 20L steel pails (approx. 20kg).
4 and 1 litre cans.

The standard contact brushing, spray grade and rolling adhesive for fixing to the substrate and for laps not subject to periodic ponding.

SAFETY PRECAUTIONS

ARDEX WA 98 is hazardous and a dangerous goods. It is highly flammable and harmful if swallowed. It is irritating to the eyes and skin and may cause sensitisation by skin contact. Keep container tightly closed and in a well ventilated place. Take off immediately all contaminated clothing. In case of contact with eyes, rinse with plenty of water and contact a doctor or Poisons Information Centre.

ADDITIONAL INFORMATION IS LISTED IN THE MATERIAL SAFETY DATA SHEET.

ARDEX SEAM TAPE

ARDEX Seam Tape is an uncured butyl cold gum tape for use in conjunction with ARDEX Seam Primer for bonding Butynol lap joints. ARDEX Seam Tape is suitable for laps that are likely to be subjected to periodic ponding only – not suitable for continuous immersion conditions. For continuous immersion joints must be fusion welded.

Supplied in 50mm x 30.5m rolls (6 to a carton).

ARDEX PRESSURE SEAL

Designed to seal the edges of ARDEX Butynol or ARDEX Torch Applied Bitumen (Shelterbit) Membranes and ARDEX SBS Self Adhesive (Shelterseal) Membranes where no existing cavity flashing or dampcourse has been installed.

PRODUCT DESCRIPTION

3 metre lengths of specially formed aluminium strip.

INSTALLATION

The ARDEX Pressure Seal is mechanically fixed through the top edge of the membrane at 500mm intervals. The uppermost edge of the strip is then sealed with ARDEX Butynol Sealant along the profile provided.

PACKAGING

Packs containing 10 x 3 metre lengths.

ARDEX WPM 299 SEAM PRIMER

A water resistant primer adhesive, used with seam tape for general lap bonding.

ARDEX WPM 299 Seam Primer is suitable for laps that are likely to be subjected to periodic ponding only – not suitable for continuous immersion conditions. For continuous immersion joints must be fusion welded.

Important: Temperature and Humidity

The evaporation of any solvent adhesive system causes a drop in temperature at the interface. At times of high humidity this can result in a micro molecular water layer at the interface which will result in a failure to bond, falsely attributed to adhesive failure. Fixing should not proceed under these circumstances.

NOTES

1. In cases of extreme absorbency, a priming coat of full strength ARDEX WA 98 adhesive may assist water shedding and absorption. However, a follow up coat of full strength adhesive for full bonding should not be proceeded with under four hours, thus allowing full evaporation of solvents absorbed into the substrate. Primers must be time dried not touch dried.
2. As new substrate materials continually appear on the market, consult ARDEX for approval of their use with Butynol.
3. Where periodic ponding is likely and on roofs with a slope of 5° or less, ARDEX Seam Tape and ARDEX WPM 299 Seam Primer must be used on all joints.
4. Laps can be formed on roofs with a pitch greater than 5° with normal brush grade substrate ARDEX WA 98 adhesive. Laps must be solvent wiped with ARDEX WPM 290 solvent prior to applying adhesive. They must however at all times drain dry and have no periodic ponding.
5. Do not use in temperatures less than 6°C.

FLAMMABILITY

ARDEX WPM 299 Seam Primer gives off highly flammable vapour. Keep well away from heat, sparks and open flame. Keep closed when not in use.

LIMITATIONS

Primer should be used with appropriate mask and breathing apparatus in areas of poor ventilation and/or air flow.

SAFETY PRECAUTIONS

ARDEX WPM 299 is hazardous and a dangerous goods. It is highly flammable and harmful if swallowed. It is irritating to the eyes and skin and may cause sensitisation by skin contact. Keep container tightly closed and in a well ventilated place. Take off immediately all contaminated clothing. In case of contact with eyes, rinse with plenty of water and contact a doctor or Poisons Information Centre.

ADDITIONAL INFORMATION IS LISTED IN THE MATERIAL SAFETY DATA SHEET.

ARDEX BUTYNOL SEALANT

Description

ARDEX Butynol Sealant has been specially designed and formulated for sealing Butynol flashings into chases as found in Building and Construction. Butynol Sealant gives excellent adhesion and sealant properties to both Butynol Membranes and building substrates.

FLAMMABILITY

ARDEX Butynol Sealant gives off highly flammable vapour. Keep well away from heat, sparks and open flame. Keep closed when not in use.

DIRECTIONS

Once the Butynol Membrane has been fixed into place apply an even bead of Butynol Sealant into the chase, which should be properly prepared by ensuring all surfaces are clean, dry and sound. Tool the sealant bead to ensure there are no voids, gaps or air pockets and that the bead has a neat and flush finish.

TACK FREE TIME

Approx. 24 hours, depending on temperature conditions, can be painted within 4 to 6 days.

FULL CURE TIME

4-6 days depending on temperature conditions.

CLEAN UP

Clean tools, etc., with mineral turpentine.

COLOUR

Black

LIMITATIONS

Sealant should be used with appropriate mask and breathing apparatus in areas of poor ventilation and/or air flow.

FIRST AID

Swallowed: Give water to clean mouth. Do not induce vomiting.

Skin: Remove contaminated clothing. Wash skin thoroughly with soap and water.

Eyes: Hold open and flood with water for at least 15 minutes. *Inhalation:* Remove patient to fresh air. If breathing is difficult administer oxygen.

Seek medical attention promptly.

SUBSTRATE VENTILATION

Substrate ventilation should be used to release moisture trapped under the Butynol. Substrate ventilators are used for this purpose. One way substrate ventilators prevent moisture vapour build up and one should be installed every 90 square metres. Not designed to ventilate roof cavities.

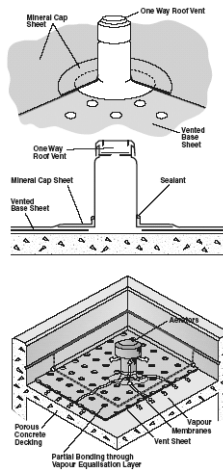

ARDEX PRESSURE SEAL

Designed to seal the edges of ARDEX Butynol or ARDEX Torch Applied Bitumen Membranes and ARDEX SBS Self Adhesive Membranes where no existing cavity flashing or dampcourse has been installed.

PRODUCT DESCRIPTION

3 metre lengths of specially formed aluminium strip.

INSTALLATION

The ARDEX Pressure Seal is mechanically fixed through the top edge of the membrane at 500mm intervals. The uppermost edge of the strip is then sealed with ARDEX Butynol Sealant along the profile provided.

PACKAGING

Packs containing 10 x 3 metre lengths.

ARDEX PROTECTION BOARD

ARDEX Protection Board is a fluted polyethylene board designed to be used after the membrane installation and prior to backfilling to protect the membrane from mechanical damage during the backfilling operation.

SIZE

1,800 X 1,200mm fluted boards.

PACKAGING

Packs of 25 boards.

THIS PAGE HAS BEEN LEFT BLANK INTENTIONALLY